



TRUCK & TRANSPORT

Gesamtsortiment

09|21



**TRUCK &
TRANSPORT**

Bohnenkamp

■ ■ ● Moving Professionals

www.bohnenkamp.com



ALLES AUS EINER HAND

Unser Produktsortiment umfasst Reifen, Räder, Felgen, Schläuche und Fahrzeugbauteile für nahezu jedes Fahrzeug und jeden Einsatz.



LKW, LLKW, TRANSPORTER, BUSSE, PKW-TRAILER



**TRUCK &
TRANSPORT**

WIR SIND IHR PARTNER RUND UM REIFEN UND RÄDER IM PROFESSIONELLEN EINSATZ!

Fordern Sie gerne weitere Produktübersichten an.
Tel. +49 541 12163-0 · info@bohenkamp.de
oder über den QR Code.



AGRAR



**ERDBEWEGUNG/
HAFEN/INDUSTRIE**



**LANDSCHAFTSPFLEGE,
HOF UND FREIZEIT**



**FAHRZEUGBAU-
SYSTEME**

STARKE MARKEN

für Truck & Transport



BK TRAILER

BOYA

BOYA TRAILER

BOYA WHEEL



Deli Tire

GT RADIAL

GKN Wheels

Jantisa

KENDA

MAXXIS
REIFEN



LKW, LLKW, TRANSPORTER, BUSSE, PKW-TRAILER



UNSER SERVICEANGEBOT

- Höchste Verfügbarkeit
- After-Sales-Service vor Ort
- Versandkostenfrei bereits bei kleinen Stückzahlen
- Online-Shop & App für 24-Stunden-Bestellungen
- Day-to-Day Lieferservice

nokian
TYRES

ONYX

SAILUN
TYRE

SEMPERIT 
Seit 1906.

TRAILERMAXX

WINDPOWER
Get Your Job Done

Alle Marken kombinierbar
als individuelles Komplettrad













Bohnenkamp
 Moving Professionals



Ihre Ansprechpartner im Innendienst











Verkauf für den Reifenhandel

Tel.: 0 541 121 63 - 200 (Sammelrufnummer)

 <p>Karsten Krückeberg Leitung Geschäftsbereich EM/Truck Durchwahl: -237 karsten.krueckeberg@bohenkamp.de</p>	 <p>Christian Pieper Stellvertreternder Bereichsleiter Durchwahl: -279 christian.pieper@bohenkamp.de</p>	 <p>Eduard Ajdinaj Durchwahl: -124 eduard.ajdinaj@bohenkamp.de</p>
 <p>Marion Beiderwellen Durchwahl: -620 marion.beiderwellen@bohenkamp.de</p>	 <p>Ralf Heidrich Durchwahl: -276 ralf.heidrich@bohenkamp.de</p>	 <p>Johannes Krämer Durchwahl: -258 johannes.kraemer@bohenkamp.de</p>
 <p>Nils Lamping Durchwahl: -238 nils.lamping@bohenkamp.de</p>	 <p>Halil Ibrahim Özen Durchwahl: -227 halilibrahim.oezen@bohenkamp.de</p>	 <p>Claudia Santos Durchwahl: -245 claudia.santos@bohenkamp.de</p>
 <p>Marcel Wesenberg Durchwahl: -272 marcel.wesenberg@bohenkamp.de</p>	 <p>Marius Zumstrull Durchwahl: -270 marius.zumstrull@bohenkamp.de</p>	

Verkauf für den Landmaschinenhandel

Tel.: 0 541 121 63 - 100 (Sammelrufnummer)

 <p>Heiko Holthaus Leitung Geschäftsbereich Agrar Durchwahl: -749 heiko.holthaus@bohenkamp.de</p>	 <p>Patrick Ostwald Stellvertreternder Bereichsleiter Durchwahl: -170 patrick.ostwald@bohenkamp.de</p>	 <p>Ulrich Langemeyer Leitung Innendienst Durchwahl: -146 ulrich.langemeyer@bohenkamp.de</p>
 <p>Mike Hartmann Durchwahl: -160 mike.hartmann@bohenkamp.de</p>	 <p>Wolfgang Hindermann Durchwahl: -168 wolfgang.hindermann@bohenkamp.de</p>	 <p>Markus Hinz Durchwahl: -171 markus.hinz@bohenkamp.de</p>
 <p>Uwe Huesmann Durchwahl: -120 uwe.huesmann@bohenkamp.de</p>	 <p>Stella-Marie Hüpel Durchwahl: -127 stella-marie.huepel@bohenkamp.de</p>	 <p>Tim Jendrik Kleine Durchwahl: -278 tim.kleine@bohenkamp.de</p>
 <p>Dennis Scholko Durchwahl: -169 dennis.scholko@bohenkamp.de</p>	 <p>Oliver Wellmann Durchwahl: -134 oliver.wellmann@bohenkamp.de</p>	

Unsere Truck- und Transport Spezialisten

Tel.: 0 541 121 63 - DW



Karsten Krückeberg
Leitung Geschäftsbereich
EM/Truck
Durchwahl: -237

karsten.krueckeberg@bohnenkamp.de



Mark Sobiech
Key Account Manager
Truck & Trailer
Mobil: +49 171 8194205

mark.sobiech@bohnenkamp.de



Nils Lamping
Durchwahl: -238

nils.lamping@bohnenkamp.de



Marius Zumstrull
Durchwahl: -270

marius.zumstrull@bohnenkamp.de



**MITARBEITER
MIT KOMPETENZ**



Ansprechpartner Niederlassungen

Vertriebsbüro Lüneburg - Pulverweg 1a · 21337 Lüneburg

Tel.: +49 (0) 41 31 29895- Durchwahl



Svend Burkhardt
Niederlassungsleiter

Durchwahl: -63

svend.burkhardt@bohnenkamp.de



Michael Kleckner

Durchwahl: -62

michael.kleckner@bohnenkamp.de



Olav Kleinow

Durchwahl: -57

olav.kleinow@bohnenkamp.de



Timo Potratz

Durchwahl: -58

timo.potratz@bohnenkamp.de



Krishanth Rajendram

Durchwahl: -56

krishanth.rajendram@bohnenkamp.de



Anja Stuhlmacher

Durchwahl: -48

anja.stuhlmacher@bohnenkamp.de



Yildiray Yalcin

Durchwahl: -51

yildiray.yalcin@bohnenkamp.de

Niederlassung Landshut · Landshuter Straße 57 · 84051 Altheim

Tel.: +49 (0) 8703 938- Durchwahl



Christopher Wagner
Niederlassungsleiter

Durchwahl: -11

christopher.wagner@bohnenkamp.de



Maximilian Bohrer

Durchwahl: -28

maximilian.bohrer@bohnenkamp.de

Niederlassung Kletzin · Dortstraße 93 · 17111 Kletzin

Tel.: +49 (0) 399 9831- Durchwahl



Eberhard Schumacher
Niederlassungsleiter

Durchwahl: -11

eberhard.schumacher@bohnenkamp.de



Cathleen Bidla

Durchwahl: -12

cathleen.bidla@bohnenkamp.de



Daniel Breitsprecher

Durchwahl: -16

daniel.breitsprecher@bohnenkamp.de



Sylvana Felgenhauer

Durchwahl: -13

sylvana.felgenhauer@bohnenkamp.de



Olaf Krause

Durchwahl: -10

olaf.krause@bohnenkamp.de

Vertriebsbüro Leipzig · Straßburger Straße 1 · 06184 Kabelsketal OT Großkugel

Tel.: +49 (0) 341 39299- Durchwahl



Henry Hoffmann

Durchwahl: -541

henry.hoffmann@bohnenkamp.de



Sebastian Liebich

Durchwahl: -544

sebastian.liebich@bohnenkamp.de

EINFACH UND MOBIL

Bohnenkamp Digital

BOHNENKAMP DIGITAL



ONLINE-SHOP

- Direkter Zugriff auf unser gesamtes Sortiment
- Alle Lagerbestände und Preise auf einen Blick
- Auf Wunsch mit eigenem Layout
- Viele hilfreiche Servicetools



ONLINE-SHOP-APP

- Der gesamte Onlineshop für Tablet und Handy
- Nutzung auch ohne Internetverbindung möglich
- Anmeldung per Fingerprint
- Für Android und Apple verfügbar



TECHNISCHER-RATGEBER-APP









- Technische Gesamtübersicht aller gängigen Reifengrößen
- Filtern nach allen wichtigen Kriterien
- Alle technischen Details für den professionellen Einsatz







Ihre Ansprechpartner vor Ort

Gebietsleiter

 <p>Markus Schmidt Mobil: +49 171 3389881 markus.schmidt@bohenkamp.de</p>	 <p>Andreas Abeln Mobil: +49 151 64959140 andreas.abeln@bohenkamp.de</p>	 <p>Julius Obermeyer Mobil: +49 151 26373004 julius.obermeyer@bohenkamp.de</p>
 <p>Eberhard Schumacher Mobil: +49 171 3042486 eberhard.schumacher@bohenkamp.de</p>	 <p>Robert Kolassa Mobil: +49 151 21665505 robert.kolassa@bohenkamp.de</p>	 <p>Dirk Lewandowski Mobil: +49 171 3389885 dirk.lewandowski@bohenkamp.de</p>
 <p>Thomas Süptitz Mobil: +49 151 56036767 thomas.sueptitz@bohenkamp.de</p>	 <p>Timo Schneider Mobil: +49 160 90602981 timo.schneider@bohenkamp.de</p>	 <p>Frank Schiff Mobil: +49 151 46756722 frank.schiff@bohenkamp.de</p>
 <p>Peter Funk Mobil: +49 171 9751633 peter.funk@bohenkamp.de</p>	 <p>Martin Scharf Mobil: +49 171 5685374 martin.scharf@bohenkamp.de</p>	 <p>Bernd Wilke Mobil: +49 171 3389888 bernd.wilke@bohenkamp.de</p>
 <p>Stephan Gajda Mobil: +49 151 57315357 stephan.gajda@bohenkamp.de</p>	 <p>Matthias Löhning Mobil: +49 175 2278937 matthias.loehning@bohenkamp.de</p>	

Key Account Management

 <p>Christian Bode Key Account Manager OE Nord Mobil: +49 151 21208591 christian.bode@bohenkamp.de</p>	 <p>Sven van Buer Key Account Manager OEM - EM & Industrie Mobil: +49 151 11165660 sven.vanbuer@bohenkamp.dee</p>	 <p>Çağlar Tosun Key Account Manager OE Süd Mobil: +49 170 7646107 caglar.tosun@bohenkamp.de</p>
 <p>Timo Schneider Key Account Manager EM & Industrie Nord Mobil: +49 160 90602981 timo.schneider@bohenkamp.de</p>	 <p>Joachim Schippan Key Account Manager EM & Industrie Süd Mobil: +49 170 1447479 joachim.schippan@bohenkamp.de</p>	 <p>Mark Sobiech Key Account Manager Truck & Trailer Mobil: +49 171 8194205 mark.sobiech@bohenkamp.de</p>
 <p>Svend Burkhardt Key Account Manager Kommunal & Powersport Tel: +49 4131 29895 63 svend.burkhardt@bohenkamp.de</p>		

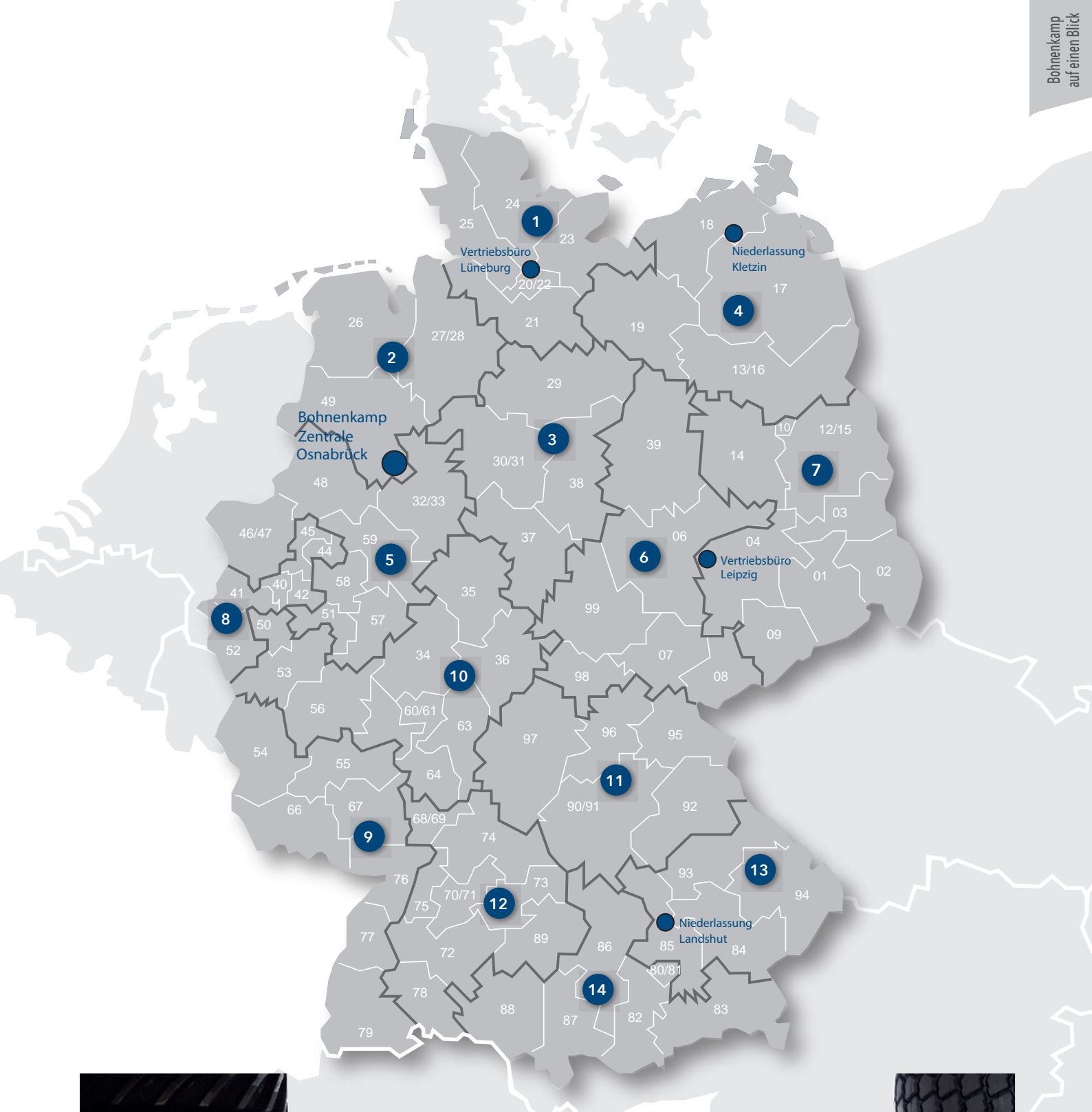

UNSERE GEBIETSLEITER

Wir sind jederzeit mit Rat und Tat an Ort und Stelle für Sie da

VERSAND UND FRACHTKOSTEN

BOHNENKAMP LOGISTIK



24 STUNDEN

SPEDITION

Ab 200,- EUR frei Haus

Bestellannahme:

Mo. - Do. bis 15.00 Uhr / Fr. bis 14.00 Uhr:

Lieferung am nächsten Werktag*

Frachtkosten: unter 200,- EUR Auftragswert 8,- EUR



24 STUNDEN
PAKETDIENST

PAKETDIENST

Ab 200,- EUR frei Haus

Bestellannahme:

Mo. - Do. bis 16.00 Uhr / Fr. bis 15.00 Uhr:

Lieferung am nächsten Werktag*

Frachtkosten: unter 200,- EUR Auftragswert 8,- EUR



EXPRESS
8.00 Uhr

NACHTVERTEILSERVICE

Bestellannahme:

Mo. - Do. bis 16.00 Uhr / Fr. bis 15.00 Uhr:

Lieferung nächster Werktag bis 8:00 Uhr

Frachtkosten: unfrei - Preisbestätigung der Versandkosten



SEMPERIT REIFEN	16
Vorderachse	18
Antriebsachse	20
Trailer	22
Bus	22
NOKIAN REIFEN	24
Vorderachse	26
Antriebsachse	28
Trailer	30
WINDPOWER REIFEN	32
Vorderachse	34
Antriebsachse	38
Trailer	42
RE-Power (runderneuert)	44
All Position	46
SAILUN REIFEN	50
Vorderachse	52
Antriebsachse	54
Trailer	56
All Position	60
Bus	60
BOKA REIFEN	62
LKW Reifen diagonal	64
ONYX LLKW REIFEN	68
All Season	70
Winter	70
Sommer	72
SAILUN LLKW REIFEN	74
All Season	76
Winter	76

PKW - TRAILER REIFEN	78
PKW - Trailer	80
LKW FELGEN	96
LKW Felgen Aluminium Accuride	98
LKW Felgen Aluminium Zubehör	100
LKW Felgen Stahl	102
LLKW- UND TRAILERFELGEN	112
LLKW Felgen Stahl	114
PKW Trailerfelgen Aluminium	115
PKW Trailerfelgen Stahl	116
PKW Trailerfelgen Aluminium/Stahl Zubehör	119
RÄDER	120
LKW Räder Stahl Nokian	122
LKW Räder Stahl Windpower	124
LKW Räder Stahl Sailun	126
LKW Räder Aluminium Nokian	128
PKW Trailer Räder Stahl	130
PKW Trailer Räder Aluminium	134
ZUBEHÖR	136
Ventile	138
Zubehör	140
Montagezubehör und Werkzeug	142
TECHNISCHE INFORMATIONEN	144
Grundlagen Reifen	146
Grundlagen Felgen	152

Alle Bohnenkamp-Standorte sind ISO zertifiziert

Hinweis: Diese Produktübersicht wurde mit großer Sorgfalt erstellt. Trotzdem können wir für eventuelle Fehler in der Produktbeschreibung oder in den technischen Daten keine Gewähr übernehmen. Änderungen im Design bzw. technische Weiterentwicklungen vorbehalten. Im Übrigen gelten unsere Verkaufs-, Lieferungs- und Zahlungsbedingungen.



Unsere Lieferungs- und Zahlungsbedingungen finden Sie unter: www.bohnenkamp.com

* Gemäß Regellaufzeit der beauftragten Dienstleister Irrtümer vorbehalten



TRUCK & TRANSPORT

Das neue REIFEN-LABEL

ab Mai 2021

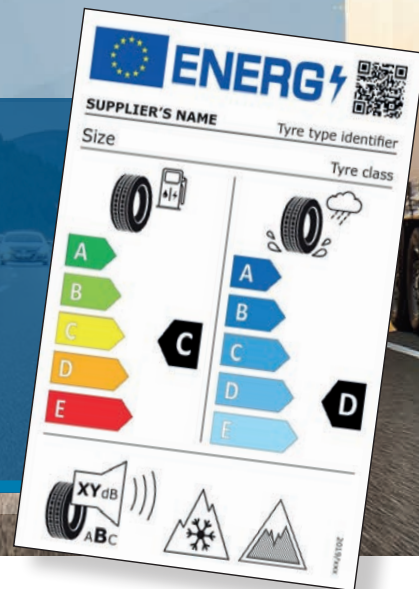

ALLGEMEINE ERKLÄRUNG

Mit der Einführung des EU-Labels sollen die Fahrzeugemissionen reduziert und somit ein Beitrag zur Klimaneutralität 2050 geleistet werden.

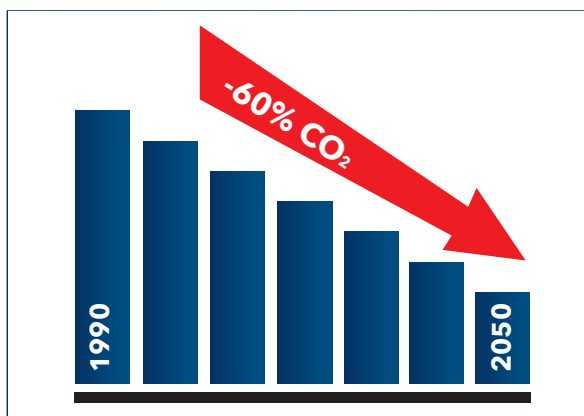

Für die bewusste Kaufentscheidung der Verbraucher gilt für Reifen der Klassen C1, C2 und C3 ab Produktionsdatum 01.05.2021 ein neues Reifenlabel, welches umfassend über die Einstufungen zum Rollwiderstand, zur Nasshaftung und zum Rollgeräusch informiert. Zusätzlich können die individuellen Reifendaten über einen QR-Code, der auf dem neuen EU-Reifenlabel angegeben ist, der EU-Datenbank (EPREL) entnommen werden.

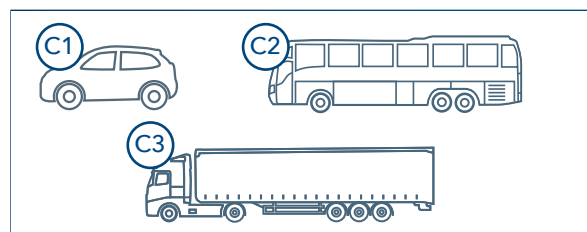

Einteilung der Klassen in C1, C2 und C3*

* hiervon ausgenommen sind Reifen mit einer zulässigen Geschwindigkeit von weniger als 80 km/h



BEDEUTUNG DER SYMBOLE

ROLLWIDERSTAND

Klassen von E bis A



Der Kraftstoffverbrauch ist vom Rollwiderstand der Bereifung, dem Fahrzeug und den Fahrbedingungen abhängig. Der Rollwiderstand wird in den Klassen A (größte Effizienz) bis E (geringste Effizienz) angegeben. Der Unterschied zwischen der günstigsten Klasse (A) und der ungünstigsten Klasse (E) liegt bei einer Verbrauchsreduzierung von 7,5%.

NASSHAFTUNG

Klassen von E bis A



Die Bremsleistung eines Reifens auf nasser Fahrbahn wird durch den (ABS-) Bremsweg oder den maximalen Reibwert zwischen dem Reifen und der Fahrbahn gemessen und mit den Werten eines Referenzreifens verglichen. Die Nasshaftung wird ebenfalls in den Klassen A (kürzester Bremsweg) und E (längster Bremsweg) angegeben. Mit einer Bereifung der Klasse A kann im Vergleich zu einem Reifen der Klasse E bei einer Vollbremsung mit 80 km/h ein bis zu 18 m kürzerer Bremsweg erreicht werden.

ROLLGERÄUSCH

Klassen von C bis A



Das Rollgeräusch des Reifens wird in den Klassen A (leisester Reifen) und C (lautester Reifen) sowie mit einer entsprechenden Anzahl an Schallwellen angegeben. Das Piktogramm mit der Klassifizierung A weist darauf hin, dass das externe Rollgeräusch des Reifens den bis 2016 geltenden EU-Grenzwert um mehr als 3 dB unterschreitet. Die Klassifizierung B unterschreitet oder entspricht dem bis 2016 geltenden EU-Grenzwert von 3 dB. Die Klassifizierung C überschreitet den bis 2016 geltenden EU-Grenzwert von 3 dB.

SCHNEE- U. EIS-PIKTOGRAMM



Das neue EU-Label wird zusätzlich das bereits bekannte Schneegriff-Piktogramm (3PMSF) für Winter- und Ganzjahresreifen sowie ein Eisgriff-Piktogramm für ausgewählte C1 PKW-Winterreifen abbilden.



DAS NEUE EU-REIFENLABEL

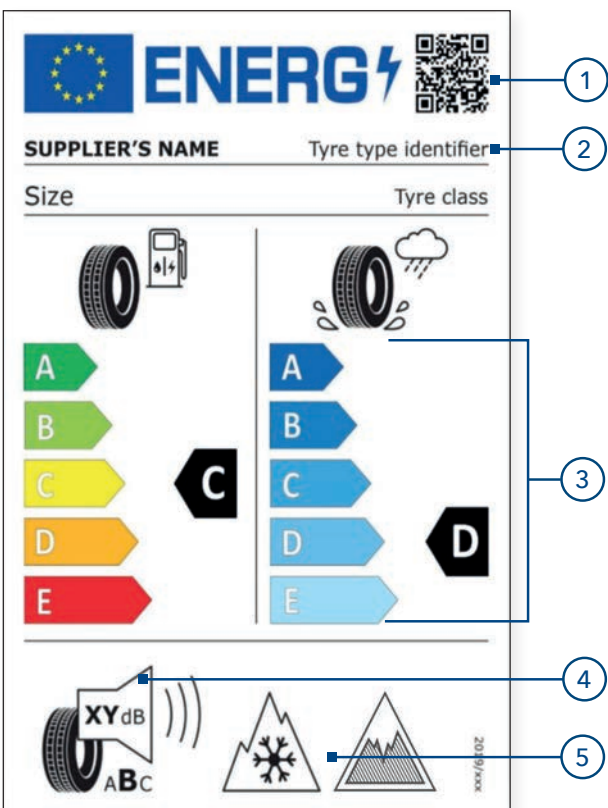

EU-Label für produzierte Reifen ab dem 01.05.2021

- 1 **QR-Code leitet zur EU-Produktdatenbank (EPREL)**
- 2 **Zusatz der Reifentypkennung = Art.-Nr.**
- 3 **Neuskalierung der unteren Labelwerte**
Die Label-Klassen E und F werden zu der Label-Klasse D. Die Label-Klasse G fusioniert zur Label-Klasse E. Auf der linken Seite des Reifenlabels erfolgt die Angabe des Rollwiderstands. Auf der rechten Seite die Angabe der Nasshaftung.
- 4 **ABC-Klassifizierung der Geräusche-Klassen anstatt Schallwellen**
Der Dezibel-Wert wird weiterhin angegeben
- 5 **Darstellung der Piktogramme**
Angabe des Schneegriffigkeit-Piktogramms (3PMSF) und Eisgriffigkeit-Piktogramms (nur für Reifen der Klasse C1)

AUFGABEN FÜR SIE ALS REIFENHÄNDLER

Wichtig ist:
Aufgrund der Übergangsphase werden noch Reifen mit dem „alten“ EU-Reifenlabel im Umlauf sein, die vor dem 01.Mai 2021 produziert wurden. Diese müssen nicht neu beklebt werden, da diese nicht von der Verordnung betroffen sind.

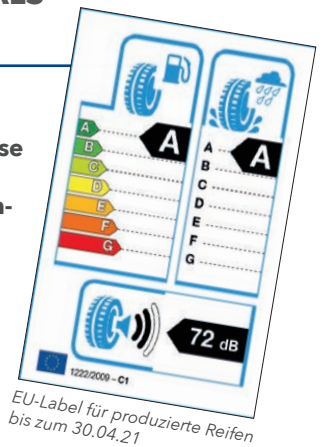

EU-Label für produzierte Reifen bis zum 30.04.21

AUFGABEN FÜR SIE ALS REIFENHÄNDLER:

- Am Verkaufsort (POS) ist das Label auf dem Reifen gut sichtbar zu platzieren. Das Produktinformationsblatt muss digital abrufbar sein und auf Anfrage in gedruckter Form bereitgestellt werden.
- Wenn Sie einen Reifen verkaufen, der Teil eines Postens aus mehreren identischen Reifen bildet, müssen sowohl Reifenlabel als auch Produktdatenblatt (digital) abrufbar sein und auf Anfrage in gedruckter Form bereitgestellt werden.
- In visuellen Anzeigen und jeglichem sonstigen Werbematerial für einen bestimmten Reifentyp muss das Reifenlabel digital oder in gedruckter Form gezeigt werden. Wird eine Reifenserie zum Beispiel als Reifenprofil angegeben, reicht die Darstellung der Bandbreite zwischen dem Reifentyp mit der schlechtesten und der besten Einstufung innerhalb der Produktfamilie.

DIE EPREL-DATENBANK

Das neue Produktdatenblatt (kurz PIS) wird in der EPREL-Datenbank von jedem Reifenhersteller hinterlegt. Es enthält alle Informationen, die auf dem EU-Reifenlabel ausgewiesen sind. Zusätzlich ist das Produktionsstartdatum und das Produktionsenddatum des Herstellers angegeben.

Product Information Sheet	
Delegated Regulation (EU) 2020/740	
Supplier name or trademark	SKATON
Commercial name or trade description	ST8
Tyre type identifier	155-310000485
Tyre size designation	205/225R17 109H
Load capacity index (for single mounting)	100
Speed category symbol	V
Fuel efficiency class	C
Wear class	C
External rolling noise class	B
External rolling noise value	71 dB
Severe wear type	No
Date of start of production	04/2021
Date of end of production	-
Additional information:	
Load capacity index for Additional Service Description (for single mounting)	108
Load capacity index for Additional Service Description (for dual mounting)	
Speed category symbol for Additional Service Description	L

SEMPERIT



Seit 1906.

Semperit. Eine Marke von Continental.



SEMPERIT REIFEN



SERVICE-PLUS BY BOHNENKAMP

Erhalten Sie direkten Zugriff
auf unseren Online-Shop



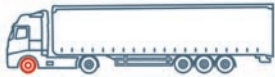

Vorderachse

Artikel-Nr.	Größe	Last-/Speed Index standard optional	TT/TL	Profil	empfohlene Felge	Außen Ø in mm	Breite in mm
109.66.100	8.5 R 17.5	121/120 L	TL	Runner F2	6.00	817	216
109.66.115	205/75 R 17.5	124/122 M	TL	Runner F2	6.00	765	205
109.66.130	215/75 R 17.5	126/124 M	TL	Runner F2	6.00	779	215
109.66.140	225/75 R 17.5	129/127 M	TL	Runner F2	6.75	797	225
109.66.155	235/75 R 17.5	132/130 M	TL	Runner F2	6.75	811	235
109.66.175	245/70 R 17.5	136/134 M	TL	Runner F2	6.75	803	245
109.66.190	245/70 R 19.5	136/134 M	TL	Runner F2	6.75	853	245
109.66.215	265/70 R 19.5	140/138 M	TL	Runner F2	7.50	881	265
109.66.230	285/70 R 19.5	146/144 M	TL	Runner F2	8.25	911	285
109.66.340	295/80 R 22.5	154/149 M	TL	Runner F2	8.25	1062	295
109.66.411	315/70 R 22.5	156/150 L 154/150 M	TL	Runner F2	9.00	1032	315
109.66.440	315/80 R 22.5	156/150 L 154/150 M	TL	Runner F2	9.00	1096	315
109.66.460	315/80 R 22.5	156/150 K	TL	Worker F2	9.00	1096	315
109.66.525	385/55 R 22.5	160 K 158 L	TL	Runner F2	11.75	1012	385
109.66.535	385/65 R 22.5	160 K 158 L	TL	Runner F2	11.75	1092	385



Semperit Runner F2

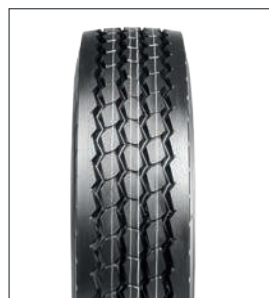

Semperit Worker F2

Informationen zum EU-Reifenlabel
erhalten Sie auf den Seiten 14 und 15.

								M+S		
Profiltiefe in mm	Tragfähigkeit (kg)		Luftdruck (bar)		Rollwider- stand	Nass- haftung	Rollgeräusch Level	M+S	3 PMSF	
	Einzel	Zwilling	Einzel	Zwilling			dB			
12,2	1450	1400	6,50	6,50	D	C	A	71	x	x
11,5	1600	1500	7,50	7,50	D	C	A	71	x	x
12,5	1700	1600	7,00	7,00	D	C	A	71	x	x
11,9	1850	1750	7,50	7,50	C	D	A	71	x	x
12,4	2000	1900	8,00	8,00	D	C	A	71	x	x
12,9	2240	2120	8,50	8,50	D	C	A	71	x	x
12,4	2240	2120	8,50	8,50	D	B	A	71	x	x
12,9	2500	2360	8,00	8,00	D	B	A	71	x	x
13,4	3000	2825	8,50	8,50	D	B	A	71	x	x
14,3	3750	3250	8,50	8,50	C	B	A	69	x	x
14,8	4000	3350	9,00	9,00	C	B	A	71	x	x
15,3	4000	3350	9,00	9,00	C	B	A	69	x	x
16,2	4000	3350	9,00	9,00	C	B	B	72	x	x
13,4	4500		9,00		C	B	B	73	x	x
14,3	4500		9,00		C	B	B	73	x	x

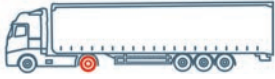

Antriebsachse

Artikel-Nr.	Größe	Last-/Speed Index standard optional	TT/TL	Profil	empfohlene Felge	Außen Ø in mm	Breite in mm	
109.66.105	8.5 R 17.5	121/120 L	TL	Runner D2	6.00	817	216	
109.66.120	205/75 R 17.5	124/122 M	TL	Runner D2	6.00	765	205	
109.66.135	215/75 R 17.5	126/124 M	TL	Runner D2	6.00	779	215	
109.66.145	225/75 R 17.5	129/127 M	TL	Runner D2	6.75	797	225	
109.66.160	235/75 R 17.5	132/130 M	TL	Runner D2	6.75	811	235	
109.66.180	245/70 R 17.5	136/134 M	TL	Runner D2	6.75	803	245	
109.66.300	11 R 22.5	148/145 L	TL	M470 Trans-Steel	8.25	1070	279	
109.66.310	13 R 22.5	156/150 K	TL	Worker D2	9.00	1146	330	
109.66.330	295/60 R 22.5	150/147 L	TL	Euro-Drive	9.00	940	295	
109.66.345	295/80 R 22.5	152/148 M	TL	Runner D2	8.25	1062	295	
109.66.375	315/60 R 22.5	152/148 L	TL	Euro-Drive	9.00	966	315	
109.66.415	315/70 R 22.5	154/150 L	152/148 M	TL	Runner D2	9.00	1032	315
109.66.445	315/80 R 22.5	156/150 L	154/150 M	TL	Runner D2	9.00	1096	315
109.66.465	315/80 R 22.5	156/150 K	TL	Worker D2	9.00	1096	315	



Semperit Euro-Drive



**Semperit M470
Trans-Steel**

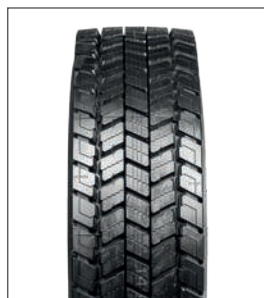

Semperit Runner D2

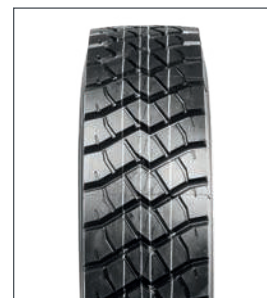

Semperit Worker D2

Informationen zum EU-Reifenlabel erhalten Sie auf den Seiten 14 und 15.

Profiltiefe in mm	Tragfähigkeit (kg)		Luftdruck (bar)		Rollwider- stand	Nass- haftung	Rollgeräusch		M+S	3 PMSF
	Einzel	Zwilling	Einzel	Zwilling			Level	dB		
15,3	1450	1400	6,50	6,50	E	C	B	74	x	x
14,3	1600	1500	7,50	7,50	D	C	B	74	x	x
15,3	1700	1600	7,00	7,00	D	C	B	74	x	x
14,8	1850	1750	7,50	7,50	D	C	B	74	x	x
15,3	2000	1900	8,00	8,00	D	C	B	74	x	x
15,8	2240	2120	8,50	8,50	D	C	B	74	x	x
20,1	3150	2900	8,50	8,50	E	C	B	76	x	x
19,6	4000	3350	9,00	9,00	D	B	B	75	x	x
18,6	3350	3075	9,00	9,00	D	C	B	76	x	x
19,1	3550	3150	8,50	8,50	D	C	A	73	x	x
18,6	3550	3150	9,00	9,00	D	C	B	76	x	x
18,1	3750	3350	9,00	9,00	D	C	A	73	x	x
19,6	4000	3350	9,00	9,00	D	C	A	73	x	x
19,6	4000	3350	9,00	9,00	D	B	B	75	x	x

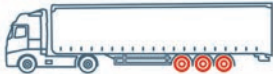

Trailer

Artikel-Nr.	Größe	Last-/Speed Index standard optional	TT/TL	Profil	empfohlene Felge	Außen Ø in mm	Breite in mm
109.66.055	7.50 R 15	135/133 G	TT	M422 Trailer-Steel	6.00	784	191
109.66.070	8.25 R 15	142/141 G	TT	M222 Trailer-Steel	6.50	848	210
109.66.125	215/75 R 17.5	135/133 K	TL	Runner T2	6.00	779	215
109.66.150	235/75 R 17.5	143/141 K	TL	Runner T2	6.75	811	235
109.66.165	245/70 R 17.5	143/141 L	TL	Runner T2	6.75	803	245
109.66.185	245/70 R 19.5	141/140 K	TL	Runner T2	6.75	853	245
109.66.206	265/70 R 19.5	143/141 J	TL	Worker T2	7.50	881	265
109.66.210	265/70 R 19.5	143/141 J	TL	M223	7.50	881	265
109.66.225	285/70 R 19.5	150/148 K	TL	Runner T2	8.25	911	285
109.66.250	445/45 R 19.5	160 J	TL	Runner T2	14.00	911	445
109.66.530	385/55 R 22.5	160 K	TL	Runner T2	11.75	1012	385
109.66.540	385/65 R 22.5	160 K	TL	Runner T2	11.75	1092	385
109.66.550	385/65 R 22.5	160 K	TL	M277	11.75	1092	385



Bus

Artikel-Nr.	Größe	Last-/Speed Index standard optional	TT/TL	Profil	empfohlene Felge	Außen Ø in mm	Breite in mm
109.66.320	275/70 R 22.5	150/145 J	TL	City A2	7.50	974	275



Semperit City A2



Semperit M222
Trailer-Steel



Semperit M223

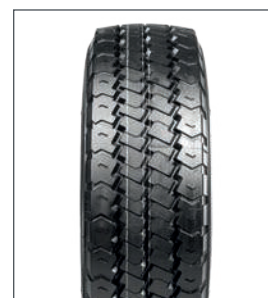

Semperit M277

Informationen zum EU-Reifenlabel erhalten Sie auf den Seiten 14 und 15.

Profiltiefe in mm	Tragfähigkeit (kg)		Luftdruck (bar)		Rollwider- stand	Nass- haftung	Rollgeräusch Level	dB	M+S	
	Einzel	Zwilling	Einzel	Zwilling					M+S	3 PMSF
12,2	2180	2060	8,50	8,50	D	C	A	70		
12,6	2650	2575	8,50	8,50	C	C	B	71		
11,9	2180	2060	9,00	9,00	D	C	A	69	x	
11,5	2725	2575	9,00	9,00	C	C	A	69	x	
11,5	2725	2575	9,00	9,00	C	C	A	69	x	
12,4	2575	2500	8,50	8,50	C	C	A	70	x	
15,8	2725	2575	8,50	8,50	D	B	A	73	x	x
12,9	2725	2575	8,50	8,50	D	C	B	71	x	
13,4	3350	3150	9,00	9,00	C	C	A	70	x	
12,4	4500		9,00		B	C	B	72	x	
13,4	4500		9,00		B	B	A	70	x	
15,3	4500		9,00		C	B	A	69	x	
16,2	4500		9,00		C	C	B	75	x	

Profiltiefe in mm	Tragfähigkeit (kg)		Luftdruck (bar)		Rollwider- stand	Nass- haftung	Rollgeräusch Level	dB	M+S	
	Einzel	Zwilling	Einzel	Zwilling					M+S	3 PMSF
19,5	3350	2900	9,00	9,00	D	B	B	72	x	x



Semperit M422
Trailer-Steel



Semperit Runner T2



Semperit Worker T2

nokian[®]
TYRES



NOKIAN REIFEN



SERVICE-PLUS BY BOHNENKAMP

Erhalten Sie direkten Zugriff
auf unseren Online-Shop



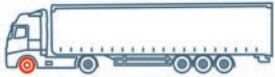

Vorderachse



TL/
TT



Artikel-Nr.	Größe	Last-/Speed Index standard optional	TT/TL	Profil	empfohlene Felge	Außen Ø in mm	Breite in mm	
174.66.251	215/75 R 17.5	126/124 M	TL	E-Truck Steer	6.00	761	212	
174.66.256	235/75 R 17.5	132/130 M	TL	E-Truck Steer	6.75	791	238	
174.66.300	265/70 R 19.5	143/141 J	TL	Hakka Truck 844+	7.50	872	251	
174.66.315	275/70 R 22.5	148/145 L	TL	Hakka Truck 844+	8.25	964	272	
174.66.336	295/80 R 22.5	154/149 M	TL	Hakkapeliitta Truck F2	9.00	1054	297	
174.66.500	295/80 R 22.5	152/148 M	TL	E-Truck Steer	9.00	1044	298	
174.66.360	315/60 R 22.5	154/148 L	TL	Hakka Truck Steer	9.00	959	314	
174.66.510	315/70 R 22.5	154/150 L	152/148 M	TL	E-Truck Steer	9.00	1019	318
174.66.373	315/70 R 22.5	156/150 L	154/150 M	TL	Hakkapeliitta Truck F2	9.00	1021	312
174.66.365	315/70 R 22.5	156/150 L	154/150 M	TL	Hakka Truck Steer	9.00	1021	312
174.66.406	315/80 R 22.5	156/150 K	TL	R-Truck Steer	9.00	1082	309	
174.66.401	315/80 R 22.5	156/150 L	154/150 M	TL	Hakkapeliitta Truck F2	9.00	1078	312
174.66.400	315/80 R 22.5	156/150 L	154/150 M	TL	Hakka Truck Steer	9.00	1079	314
174.66.520	315/80 R 22.5	156/150 L	154/150 M	TL	E-Truck Steer	9.00	1071	314
174.66.433	385/55 R 22.5	160 K	TL	Hakka Truck Steer	11.75	1005	384	
174.66.430	385/55 R 22.5	160 K	158 L	TL	Hakka Truck 844	11.75	1002	384
174.66.432	385/55 R 22.5	160 K	158 L	TL	Hakkapeliitta Truck F2	11.75	996	386
174.66.451	385/65 R 22.5	164 K	TL	Hakkapeliitta Truck F2 XL	11.75	1084	381	
174.66.452	385/65 R 22.5	160 K	TL	E-Truck Steer	11.75	1078	378	
174.66.453	385/65 R 22.5	164 K	TL	R-Truck Steer XL	11.75	1086	381	
174.66.446	385/65 R 22.5	160 K	158 L	TL	Hakkapeliitta Truck F2	11.75	1086	376
174.66.447	385/65 R 22.5	160 K	TL	R-Truck Steer	11.75	1086	378	
174.66.445	385/65 R 22.5	160 K	158 L	TL	Hakka Truck Steer	11.75	1083	376



Nokian E-Truck Steer

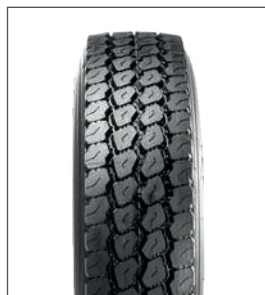

Nokian R-Truck Steer



Nokian Hakka Truck 844/
Hakka Truck 844+

Informationen zum EU-Reifenlabel erhalten Sie auf den Seiten 14 und 15.

Profiltiefe in mm	Tragfähigkeit (kg)		Luftdruck (bar)		Rollwider- stand	Nass- haftung	Rollgeräusch Level	dB	M+S	3 PMSF
	Einzel	Zwilling	Einzel	Zwilling						
11,7	1700	1600	8,50	8,50	C	C	A	70	x	x
12,2	2000	1900	8,75	8,75	C	B	A	67	x	x
14,0	2725	2575	8,50	8,50	D	B	A	69	x	x
14,5	3150	2900	9,00	9,00	C	B	A	67	x	x
16,0	3750	3250	8,50	8,50	D	B	A	71	x	x
13,5	3550	3150	8,50	8,50	C	B	A	70	x	x
13,0	3750	3150	9,00	9,00	C	B	B	72	x	x
13,5	3750	3350	9,00	9,00	C	A	A	70	x	x
15,5	4000	3350	9,00	9,00	D	C	A	71	x	x
14,0	4000	3350	9,00	9,00	C	B	A	70	x	x
16,0	4000	3350	8,25	8,25	C	B	A	70	x	x
16,0	4000	3350	8,50	8,50	D	B	B	73	x	x
15,5	4000	3350	8,50	8,50	D	B	A	70	x	x
14,5	4000	3350	8,50	8,50	C	A	A	69	x	x
15,5	4500		9,00		D	C	A	70	x	x
15,0	4500		9,00		D	B	B	72	x	x
15,5	4500		9,00		D	B	B	74	x	x
16,0	5000		9,00		C	B	B	75	x	x
13,5	4500		9,00		C	B	A	71	x	x
16,0	5000		9,00		C	C	A	70	x	x
16,0	4500		9,00		E	B	B	73	x	x
16,0	4500		9,00		C	B	A	71	x	x
15,5	4500		9,00		C	B	A	70	x	x



Nokian Hakka Truck Steer



Nokian Hakkapeliitta Truck F2/
Hakkapeliitta Truck F2 XL

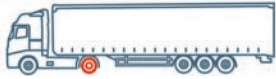

Antriebsachse



TL/
TT



Artikel-Nr.	Größe	Last-/Speed Index standard optional	TT/TL	Profil	empfohlene Felge	Außen Ø in mm	Breite in mm	
174.66.252	215/75 R 17.5	126/124 M	TL	E-Truck Drive	6.00	763	213	
174.66.257	235/75 R 17.5	132/130 M	TL	E-Truck Drive	6.75	791	238	
174.66.316	275/70 R 22.5	148/145 M	TL	Hakkapeliitta Truck D	8.25	958	276	
174.66.320	295/60 R 22.5	150/147 L	TL	Hakka Truck Drive	9.00	931	299	
174.66.338	295/80 R 22.5	152/148 M	TL	Hakkapeliitta Truck D	9.00	1063	296	
174.66.340	295/80 R 22.5	152/148 M	TL	Hakkapeliitta Truck E2	9.00	1064	297	
174.66.505	295/80 R 22.5	152/148 M	TL	E-Truck Drive	9.00	1044	298	
174.66.361	315/60 R 22.5	152/148 L	TL	Hakka Truck Drive	9.00	963	311	
174.66.515	315/70 R 22.5	154/150 L	152/148 M	TL	E-Truck Drive	9.00	1027	314
174.66.371	315/70 R 22.5	152/148 M	154/150 L	TL	Hakkapeliitta Truck D	9.00	1032	314
174.66.374	315/70 R 22.5	154/150 L	152/148 M	TL	Hakkapeliitta Truck E2	9.00	1027	314
174.66.385	315/70 R 22.5	152/148 M	154/150 L	TL	Hakka Truck Drive	9.00	1029	314
174.66.407	315/80 R 22.5	156/150 L	154/150 M	TL	Hakkapeliitta Truck E2	9.00	1089	314
174.66.404	315/80 R 22.5	156/150 K	TL	R-Truck Drive	9.00	1076	312	
174.66.402	315/80 R 22.5	154/150 M	156/150 L	TL	Hakkapeliitta Truck D	9.00	1087	312
174.66.420	315/80 R 22.5	154/150 M	156/150 L	TL	Hakka Truck Drive	9.00	1085	312
174.66.525	315/80 R 22.5	154/150 M	156/150 L	TL	E-Truck Drive	9.00	1081	314



Nokian E-Truck Drive



Nokian R-Truck Drive



Nokian Hakka Truck Drive



**Nokian Hakkapeliitta
Truck D**

Informationen zum EU-Reifenlabel erhalten Sie auf den Seiten 14 und 15.

Profiltiefe in mm	Tragfähigkeit (kg)		Luftdruck (bar)		Rollwider- stand	Nass- haftung	Rollgeräusch Level	dB	M+S	
	Einzel	Zwilling	Einzel	Zwilling					M+S	3 PMSF
13,4	3550	3150	8,50	8,50	D	D	A	72	x	x
13,8	2000	1900	8,75	8,75	D	C	A	72	x	x
16,5	3150	2900	9,00	9,00	D	B	B	75	x	x
15,0	3350	3075	9,00	9,00	D	C	B	76	x	x
20,0	3550	3150	8,50	8,50	D	C	B	74	x	x
19,5	3550	3150	8,50	8,50	D	D	B	74	x	x
17,5	3550	3150	8,50	8,50	D	C	B	75	x	x
15,5	3550	3150	9,00	9,00	C	C	B	76	x	x
17,5	3750	3350	9,00	9,00	D	B	A	73	x	x
19,5	3550	3150	8,50	8,50	D	C	A	73	x	x
18,5	3750	3350	9,00	9,00	D	D	B	74	x	x
18,0	3550	3150	8,50	8,50	D	C	B	75	x	x
20,0	4000	3350	8,50	8,50	D	D	A	73	x	x
21,5	4000	3350	8,25	8,25	D	C	B	75	x	x
20,0	3750	3350	8,50	8,50	D	D	B	76	x	x
18,5	3750	3350	8,25	8,25	D	C	B	74	x	x
17,5	3750	3350	8,25	8,25	D	B	B	76	x	x



Nokian Hakkapeliitta
Truck E2

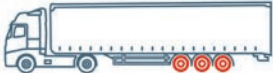

Trailer



Artikel-Nr.	Größe	Last-/Speed Index standard optional	TL/ TT	Profil	empfohlene Felge	Außen Ø in mm	Breite in mm	
174.66.253	215/75 R 17.5	135/133 J		TL	E-Truck Trailer	6.00	776	212
174.66.258	235/75 R 17.5	143/141 J		TL	E-Truck Trailer	6.75	805	238
174.66.290	245/70 R 17.5	143/141 J	146/146 F	TL	E-Truck Trailer	7.50	797	244
174.66.300	265/70 R 19.5	143/141 J		TL	Hakka Truck 844+	7.50	872	251
174.66.301	265/70 R 19.5	143/141 J		TL	Hakkapeliitta Truck T	7.50	867	262
174.66.302	265/70 R 19.5	143/141 J		TL	E-Truck Trailer	7.50	871	250
174.66.303	265/70 R 19.5	143/141 J		TL	R-Truck Trailer	7.50	877	252
174.66.315	275/70 R 22.5	148/145 L	-	TL	Hakka Truck 844+	8.25	964	272
174.66.317	275/70 R 22.5	148/145 K		TL	R-Truck Trailer	8.25	972	273
174.66.430	385/55 R 22.5	160 K	158 L	TL	Hakka Truck 844	11.75	1002	384
174.66.434	385/55 R 22.5	160 K	158 L	TL	E-Truck Trailer	11.75	1000	384
174.66.448	385/65 R 22.5	160 K	158 L	TL	R-Truck Trailer	11.75	1072	389
174.66.530	385/65 R 22.5	160 K	158 L	TL	E-Truck Trailer	11.75	1080	378



Nokian E-Truck Trailer

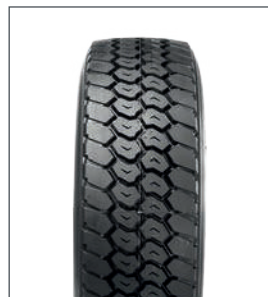

Nokian R-Truck Trailer





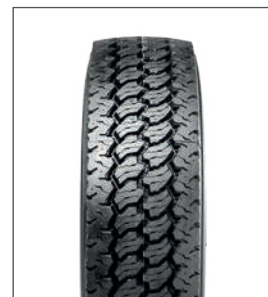





**Nokian Hakka Truck 844/
Hakka Truck 844+**



**Nokian Hakkapeliitta
Truck T**

Informationen zum EU-Reifenlabel
erhalten Sie auf den Seiten 14 und 15.

 Profiltiefe in mm	 Tragfähigkeit (kg)		 Luftdruck (bar)		 Rollwider- stand	 Nass- haftung	 Rollgeräusch Level	dB		
	Einzel	Zwilling	Einzel	Zwilling					M+S	3 PMSF
12,0	2180	2060	8,50	8,50	D	B	A	69	x	x
13,0	2725	2575	8,75	8,75	C	A	A	69	x	x
13,0	2725	2575	8,75	8,75	D	A	A	75	x	x
14,0	2725	2575	8,50	8,50	D	B	A	69	x	x
14,5	2725	2575	8,50	8,50	D	C	B	72	x	x
13,5	2725	2575	8,75	8,75	D	A	A	71	x	x
15,0	2725	2575	8,75	8,75	E	B	B	73	x	x
14,5	3150	2900	9,00	9,00	C	B	A	67	x	x
16,0	3150	2900	9,00	9,00	D	B	B	74	x	x
15,0	4500		9,00		D	B	B	71	x	x
14,5	4500		9,00		C	B	B	72	x	x
15,0	4500		9,00		C	B	B	74	x	x
15,5	4500		9,00		C	B	A	70	x	x

WINDPOWER

Get Your Job Done



WINDPOWER REIFEN

SERVICE-PLUS BY BOHNENKAMP

Erhalten Sie direkten Zugriff
auf unseren Online-Shop



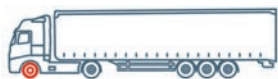

Vorderachse



Artikel-Nr.	Größe	Last-/Speed Index standard	optional	TL/ TT	Profil	empfohlene Felge	Außen Ø in mm	Breite in mm
104.66.388	7.50 R 16	122/118 L		TT	WGC 08	6.00	807	214
104.66.387	8.25 R 16	126/122 L		TT	WGC 08	6.50	850	228
104.66.466	205/75 R 17.5	124/122 M		TL	WSR 24	6.00	752	206
104.66.496	215/75 R 17.5	127/124 M		TL	WSR 24	6.00	765	216
104.66.409	215/75 R 17.5	135/133 J		TL	WGC 28	6.00	766	218
104.66.464	225/75 R 17.5	129/127 M		TL	WSR 24	6.75	781	223
104.66.465	235/75 R 17.5	132/129 M		TL	WSR 24	6.75	794	238
104.66.421	235/75 R 17.5	143/141 J		TL	WGC 28	6.75	804	236
104.66.470	245/70 R 17.5	136/134 M		TL	WSR 24	7.50	785	245
104.66.429	245/70 R 17.5	143/141 J	144/144 F	TL	WGC 28	7.50	793	252
104.66.434	265/70 R 19.5	143/141 J		TL	WGC 28	7.50	877	258
104.66.468	285/70 R 19.5	145/143 M	146/144 L	TL	WSR 36	8.25	891	280
104.68.078	8.25 R 20	136/134 K		TT	WGC 08	6.50	967	232
104.68.093	9.00 R 20	144/142 K		TT	WGC 08	7.00	1025	256
104.68.107	10.00 R 20	149/146 K		TT	WGC 08	7.50	1055	273
104.68.154	11.00 R 20	150/147 K		TT	WGC 08	8.00	1087	287
104.68.182	12.00 R 20	154/151 K		TT	WGC 08	8.50	1123	310
104.66.499	9 R 22.5	136/134 M		TL	WSR 24	6.75	968	228
104.66.509	10 R 22.5	144/142 L		TL	WGC 08	7.50	1022	252
104.66.524	11 R 22.5	146/143 M	148/145 L	TL	WSR 36	8.25	1051	277
104.66.515	11 R 22.5	146/143 L	148/145 K	TL	WGC 08	8.25	1054	281
104.66.533	12 R 22.5	152/149 M		TL	WSR 36	9.00	1072	298
104.66.527	12 R 22.5	152/149 L		TL	WGC 08	9.00	1076	303



Windpower WGC 08



Windpower WGC 28

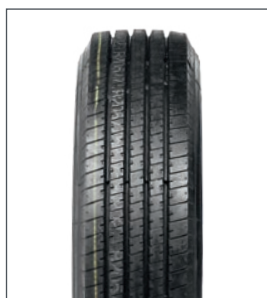

Windpower WSR 24



Windpower WSR 36

Informationen zum EU-Reifenlabel erhalten Sie auf den Seiten 14 und 15.

Profiltiefe in mm	Tragfähigkeit (kg)		Luftdruck (bar)		Rollwider- stand	Nass- haftung	Rollgeräusch		M+S	3 PMSF	Bemerkung
	Einzel	Zwilling	Einzel	Zwilling			Level	dB			
13,0	1500	1320	7,70	7,70	E	B	B	73	x	x	Set
13,0	1700	1500	6,70	6,70	D	C	B	72	x	x	Set
13,0	1550	1450	7,60	7,60	D	B	B	73	x	x	
13,0	1750	1600	8,30	8,30	D	B	B	73	x	x	
15,5	2180	2060	8,30	8,30	E	C	B	73	x	x	
15,0	1850	1750	8,30	8,30	E	B	B	74	x	x	
13,0	2000	1850	8,30	8,30	D	B	B	73	x	x	
16,5	2725	2575	9,00	9,00	E	B	B	74	x	x	
13,0	2240	2120	9,00	9,00	D	B	B	73	x	x	
16,5	2725	2575	9,00	9,00	E	B	B	74	x	x	
17,5	2725	2575	8,30	8,30	E	B	B	74	x	x	
14,0	2900	2725	8,30	8,30	C	C	A	71	x	x	
14,5	2240	2120	8,30	8,30	D	B	B	73	x	x	Set
15,5	2800	2650	9,00	9,00	D	B	B	74	x	x	Set
16,5	3250	3000	9,30	9,30	D	B	B	74	x	x	Set
17,0	3350	3075	8,30	8,30	C	B	B	74	x	x	Set
17,5	3750	3450	8,30	8,30	C	B	B	74	x	x	Set
14,5	2240	2120	8,30	8,30	E	B	B	73	x	x	
15,5	2800	2650	9,00	9,00	D	C	A	71	x	x	
15,0	3000	2725	8,30	8,30	C	C	A	71	x	x	
17,0	3000	2725	8,30	8,30	D	B	B	74	x	x	
16,5	3550	3250	9,30	9,30	D	C	A	71	x	x	
17,0	3550	3250	9,30	9,30	D	B	B	74	x	x	

Set = Reifen + Schlauch

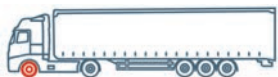

Vorderachse



TL/
TT



Artikel-Nr.	Größe	Last-/Speed Index standard	optional	TT/TL	Profil	empfohlene Felge	Außen Ø in mm	Breite in mm
104.66.699	255/70 R 22.5	140/137 M	140/140 L	TL	WSR 36	7.50	928	249
104.66.709	275/70 R 22.5	148/145 M		TL	WSR 36	8.25	962	269
104.66.607	275/70 R 22.5	148/145 M		TL	WGC 28	8.25	969	274
104.66.628	295/60 R 22.5	149/146 L	150/147 K	TL	WSL 60	9.00	916	288
104.66.718	295/80 R 22.5	154/149 M		TL	WSR 36	9.00	1046	302
104.66.702	315/70 R 22.5	156/150 L	154/150 M	TL	WSW 80	9.00	1016	302
104.66.716	315/70 R 22.5	156/150 L	154/150 M	TL	WSR 36	9.00	1018	312
104.66.763	315/80 R 22.5	158/150 L	154/150 M	TL	WSL 60	9.00	1082	317
104.66.761	315/80 R 22.5	158/150 L	154/150 M	TL	WSR 36	9.00	1082	315
104.66.719	315/80 R 22.5	158/150 L	154/150 M	TL	WSW 80	9.00	1081	316
104.66.762	315/80 R 22.5	154/151 L	156/150 K	TL	WGC 52	9.00	1082	318
104.66.760	315/80 R 22.5	154/151 L	156/150 K	TL	WGC 08	9.00	1083	316
104.66.731	385/55 R 22.5	158 L	160 K	TL	WSW 80	12.25	1004	385
104.66.591	385/55 R 22.5	158 L	160 K	TL	WGC 28	12.25	1005	384
104.66.737	385/65 R 22.5	164 K	158 L	TL	WSW 80	11.75	1064	385
104.66.736	385/65 R 22.5	160 K	158 L	TL	WGC 28	11.75	1070	387
104.66.681	425/65 R 22.5	165 K		TL	WGC 28	13.00	1121	421
104.66.698	445/65 R 22.5	169 K		TL	WGC 28	14.00	1148	450
104.68.192	12.00 R 24	160/157 K		TT	WGC 52	8.50	1224	314



Windpower WGC 08



Windpower WGC 28



Windpower WGC 52



Windpower WSL 60

Informationen zum EU-Reifenlabel erhalten Sie auf den Seiten 14 und 15.

Profiltiefe in mm	Tragfähigkeit (kg)		Luftdruck (bar)		Rollwiderstand	Nasshaftung	Rollgeräusch		M+S	3 PMSF	Bemerkung
	Einzel	Zwilling	Einzel	Zwilling			Level	dB			
14,5	2500	2300	8,30	8,30	C	C	A	71	x	x	
15,0	3150	2900	9,00	9,00	C	B	B	72	x	x	
17,5	3150	2900	9,00	9,00	D	B	B	74	x	x	
13,5	3250	3000	9,00	9,00	B	C	B	72	x	x	
15,5	3750	3250	9,00	9,00	C	B	B	73	x	x	
16,5	4000	3350	8,30	8,30	C	B	B	74	x	x	
16,5	4000	3350	8,30	8,30	B	B	B	73	x	x	
14,5	4250	3350	8,30	8,30	D	B	B	72	x	x	
16,5	4250	3350	9,00	9,00	C	C	A	71	x	x	
16,5	4250	3350	9,30	9,30	C	C	B	74	x	x	
16,5	3750	3450	8,30	8,30	C	C	B	75	x	x	
16,5	3750	3450	8,30	8,30	C	C	B	72	x	x	
13,5	4250		9,00		C	C	B	74	x	x	
17,0	4250		9,00		D	B	B	74	x	x	
13,5	5000		9,00		C	C	B	73	x	x	
16,8	4500		9,00		C	C	B	74	x	x	
16,5	5150		8,30		C	C	B	74	x	x	
16,5	5800		8,30		C	C	B	74	x	x	
17,5	4500	4125	9,00	9,00	C	B	B	74	x	x	Set

Set = Reifen + Schlauch



Windpower WSR 36



Windpower WSW 80

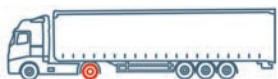

Antriebsachse



Artikel-Nr.	Größe	Last-Speed Index standard optional	TL/ TT	Profil	empfohlene Felge	Außen Ø in mm	Breite in mm
104.66.388	7.50 R 16	122/118 L	TT	WGC 08	6.00	807	214
104.66.387	8.25 R 16	126/122 L	TT	WGC 08	6.50	850	228
104.66.399	215/75 R 17.5	127/124 M	TL	WDR 09	6.00	770	215
104.66.409	215/75 R 17.5	135/133 J	TL	WGC 28	6.00	766	218
104.66.463	235/75 R 17.5	132/130 M	TL	WDR 09	6.75	800	236
104.66.421	235/75 R 17.5	143/141 J	TL	WGC 28	6.75	804	236
104.66.429	245/70 R 17.5	143/141 J 144/144 F	TL	WGC 28	7.50	793	252
104.66.434	265/70 R 19.5	143/141 J	TL	WGC 28	7.50	877	258
104.66.449	285/70 R 19.5	144/142 M 145/143 L	TL	WDR 09	8.25	896	276
104.68.078	8.25 R 20	136/134 K	TT	WGC 08	6.50	967	232
104.68.093	9.00 R 20	144/142 K	TT	WGC 08	7.00	1025	256
104.68.107	10.00 R 20	149/146 K	TT	WGC 08	7.50	1055	273
104.68.154	11.00 R 20	150/147 K	TT	WGC 08	8.00	1087	287
104.68.182	12.00 R 20	154/151 K	TT	WGC 08	8.50	1123	310
104.66.507	10 R 22.5	144/142 M	TL	WDR 55	7.50	1025	258
104.66.509	10 R 22.5	144/142 L	TL	WGC 08	7.50	1022	252
104.66.521	11 R 22.5	146/143 M 148/145 L	TL	WDR 37	8.25	1068	276
104.66.515	11 R 22.5	146/143 L 148/145 K	TL	WGC 08	8.25	1054	281
104.66.527	12 R 22.5	152/149 L	TL	WGC 08	9.00	1076	303
104.66.519	13 R 22.5	154/151 K 156/150 G	TL	WDC 53	9.75	1129	319
104.66.607	275/70 R 22.5	148/145 M	TL	WGC 28	8.25	969	274
104.66.619	275/70 R 22.5	148/145 M	TL	WDR 55	8.25	975	274
104.66.624	295/60 R 22.5	149/146 L 150/147 K	TL	WDL 60	9.00	926	288
104.66.614	315/70 R 22.5	152/148 M 154/150 L	TL	WDR 37	9.00	1030	315
104.66.700	315/70 R 22.5	152/148 M 154/150 L	TL	WDW 80	9.00	1032	312



Windpower WDC 53



Windpower WDL 60



Windpower WDR 09



Windpower WDR 37

WINDPOWER REIFEN

Informationen zum EU-Reifenlabel erhalten Sie auf den Seiten 14 und 15.

Profiltiefe in mm	Tragfähigkeit (kg)		Luftdruck (bar)		Rollwider- stand	Nass- haftung	Rollgeräusch Level	dB	M+S	3 PMSF	Bemerkung
	Einzel	Zwilling	Einzel	Zwilling							
13,0	1500	1320	7,70	7,70	E	B	B	73	x	x	Set
13,0	1700	1500	6,70	6,70	D	C	B	72	x	x	Set
16,0	1750	1600	8,30	8,30	E	C	B	74	x	x	
15,5	2180	2060	8,30	8,30	E	C	B	73	x	x	
17,0	2000	1900	8,30	8,30	D	C	A	73	x	x	
16,5	2725	2575	9,00	9,00	E	B	B	74	x	x	
16,5	2725	2575	9,00	9,00	E	B	B	74	x	x	
17,5	2725	2575	8,30	8,30	E	B	B	74	x	x	
17,0	2800	2650	8,30	8,30	D	D	B	74	x	x	
14,5	2240	2120	8,30	8,30	D	B	B	73	x	x	Set
15,5	2800	2650	9,00	9,00	D	B	B	74	x	x	Set
16,5	3250	3000	9,30	9,30	D	B	B	74	x	x	Set
17,0	3350	3075	8,30	8,30	C	B	B	74	x	x	Set
17,5	3750	3450	8,30	8,30	C	B	B	74	x	x	Set
15,5	2800	2650	9,00	9,00	D	C	A	73	x	x	
15,5	2800	2650	9,00	9,00	D	C	A	71	x	x	
22,5	3000	2725	8,30	8,30	E	C	B	74	x	x	
17,0	3000	2725	8,30	8,30	D	B	B	74	x	x	
17,0	3550	3250	9,30	9,30	D	B	B	74	x	x	
20,6	3750	3450	8,30	8,30	D	B	B	74	x	x	
17,5	3150	2900	9,00	9,00	D	B	B	74	x	x	
20,0	3150	2900	9,00	9,00	D	C	B	74	x	x	
18,0	3250	3000	9,00	9,00	D	C	A	72	x	x	
23,0	3550	3150	8,30	8,30	D	C	B	75	x	x	
24,0	3550	3150	8,30	8,30	E	C	B	74	x	x	

Set = Reifen + Schlauch



Windpower WDR 55



Windpower WDW 80

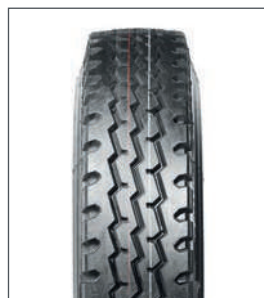

Windpower WGC 08



Windpower WGC 28

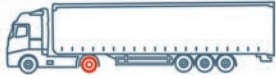

Antriebsachse



TL/
TT



Artikel-Nr.	Größe	Last-/Speed Index standard	optional	TT/TL	Profil	empfohlene Felge	Außen Ø in mm	Breite in mm
104.66.714	315/70 R 22.5	152/148 M	154/150 L	TL	WDL 60	9.00	1020	316
104.66.723	315/80 R 22.5	154/151 M	156/150 L	TL	WDC 52	9.00	1088	317
104.66.733	315/80 R 22.5	154/151 M	156/150 L	TL	WDC 53	9.00	1088	316
104.66.725	315/80 R 22.5	156/150 K		TL	WDC 55	9.00	1097	317
104.66.615	315/80 R 22.5	154/151 M	156/150 L	TL	WDR 37	9.00	1096	320
104.66.762	315/80 R 22.5	154/151 L	156/150 K	TL	WGC 52	9.00	1082	318
104.66.760	315/80 R 22.5	154/151 L	156/150 K	TL	WGC 08	9.00	1083	316
104.66.591	385/55 R 22.5	158 L	160 K	TL	WGC 28	12.25	1005	384
104.66.736	385/65 R 22.5	160 K	158 L	TL	WGC 28	11.75	1070	387
104.66.681	425/65 R 22.5	165 K		TL	WGC 28	13.00	1121	421
104.66.698	445/65 R 22.5	169 K		TL	WGC 28	14.00	1148	450
104.68.192	12.00 R 24	160/157 K		TT	WGC 52	8.50	1224	314



Windpower WDC 52



Windpower WDC 53

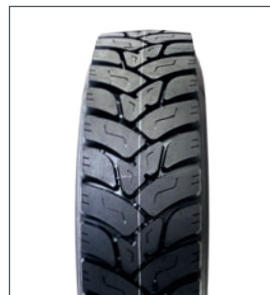

Windpower WDC 55



Windpower WDL 60

Informationen zum EU-Reifenlabel erhalten Sie auf den Seiten 14 und 15.

Profiltiefe in mm	Tragfähigkeit (kg)		Luftdruck (bar)		Rollwider- stand	Nass- haftung	Rollgeräusch Level	dB	M+S	3 PMSF	Bemerkung
	Einzel	Zwilling	Einzel	Zwilling							
18,0	3550	3150	8,30	8,30	D	B	B	74	x	x	
19,5	3750	3450	8,30	8,30	D	B	B	74	x	x	
19,5	3750	3450	8,30	8,30	D	B	B	74	x	x	
23,0	4000	3350	8,30	8,30	D	B	A	73	x	x	
23,0	3750	3450	8,30	8,30	E	C	B	74	x	x	
16,5	3750	3450	8,30	8,30	C	C	B	75	x	x	
16,5	3750	3450	8,30	8,30	C	C	B	72	x	x	
17,0	4250		9,00		D	B	B	74	x	x	
16,8	4500		9,00		C	C	B	74	x	x	
16,5	5150		8,30		C	C	B	74	x	x	
16,5	5800		8,30		C	C	B	74	x	x	
17,5	4500	4125	9,00	9,00	C	B	B	74	x	x	Set

Set = Reifen + Schlauch



Windpower WDR 37

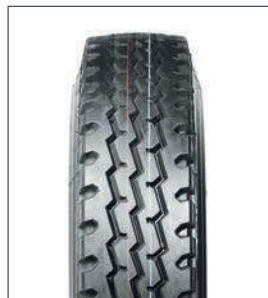

Windpower WGC 08



Windpower WGC 28

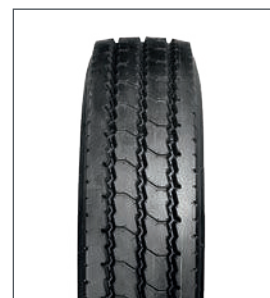

Windpower WGC 52

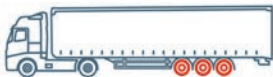

Trailer



Artikel-Nr.	Größe	Last-/Speed Index standard	optional	TL/ TT	Profil	empfohlene Felge	Außen Ø in mm	Breite in mm
104.66.388	7.50 R 16	122/118 L		TT	WGC 08	6.00	807	214
104.66.387	8.25 R 16	126/122 L		TT	WGC 08	6.50	850	228
104.66.411	215/75 R 17.5	135/133 J		TL	WTL 31	6.00	758	228
104.66.409	215/75 R 17.5	135/133 J		TL	WGC 28	6.00	766	218
104.66.415	235/75 R 17.5	143/141 J		TL	WTL 31	6.75	791	242
104.66.421	235/75 R 17.5	143/141 J		TL	WGC 28	6.75	804	236
104.66.455	245/70 R 17.5	143/141 J	146/146 F	TL	WTR 69	7.50	783	250
104.66.429	245/70 R 17.5	143/141 J	144/144 F	TL	WGC 28	7.50	793	252
104.66.454	245/70 R 19.5	141/140 J		TL	WTL 32	7.50	839	253
104.66.434	265/70 R 19.5	143/141 J		TL	WGC 28	7.50	877	258
104.66.456	285/70 R 19.5	150/148 J		TL	WTR 69	8.25	893	279
104.68.078	8.25 R 20	136/134 K		TT	WGC 08	6.50	967	232
104.68.093	9.00 R 20	144/142 K		TT	WGC 08	7.00	1025	256
104.68.107	10.00 R 20	149/146 K		TT	WGC 08	7.50	1055	273
104.68.154	11.00 R 20	150/147 K		TT	WGC 08	8.00	1087	287
104.68.182	12.00 R 20	154/151 K		TT	WGC 08	8.50	1123	310
104.66.509	10 R 22.5	144/142 L		TL	WGC 08	7.50	1022	252
104.66.515	11 R 22.5	146/143 L	148/145 K	TL	WGC 08	8.25	1054	281
104.66.527	12 R 22.5	152/149 L		TL	WGC 08	9.00	1076	303
104.66.607	275/70 R 22.5	148/145 M		TL	WGC 28	8.25	969	274
104.66.762	315/80 R 22.5	154/151 L	156/150 K	TL	WGC 52	9.00	1082	318
104.66.760	315/80 R 22.5	154/151 L	156/150 K	TL	WGC 08	9.00	1083	316
104.66.617	385/55 R 22.5	158 L	160 J	TL	WTR 69	12.25	1008	381
104.66.591	385/55 R 22.5	158 L	160 K	TL	WGC 28	12.25	1005	384



Windpower WGC 08



Windpower WGC 28



Windpower WGC 52

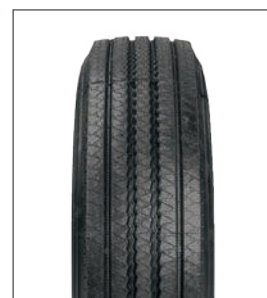

Windpower WTL 31

Informationen zum EU-Reifenlabel erhalten Sie auf den Seiten 14 und 15.

Profiltiefe in mm	Tragfähigkeit (kg)		Luftdruck (bar)		Rollwiderstand	Nasshaftung	Rollgeräusch		M+S	3 PMSF	Bemerkung
	Einzel	Zwilling	Einzel	Zwilling			Level	dB			
13,0	1500	1320	7,70	7,70	E	B	B	73	x	x	Set
13,0	1700	1500	6,70	6,70	D	C	B	72	x	x	
12,0	2180	2060	8,30	0,30	D	C	A	71	x	x	
15,5	2180	2060	8,30	8,30	E	C	B	73	x	x	
13,0	2725	2575	8,30	8,30	D	B	A	69	x	x	
16,5	2725	2575	9,00	9,00	E	B	B	74	x	x	
11,0	2725	2575	9,00	9,00	D	C	A	71	x	x	
16,5	2725	2575	9,00	9,00	E	B	B	74	x	x	
13,5	2575	2500	8,30	8,30	D	B	A	71	x	x	
17,5	2725	2575	8,30	8,30	E	B	B	74	x	x	
14,0	3350	3150	8,30	8,30	D	C	B	72	x	x	
14,5	2240	2120	8,30	8,30	D	B	B	73	x	x	Set
15,5	2800	2650	9,00	9,00	D	B	B	74	x	x	Set
16,5	3250	3000	9,30	9,30	D	B	B	74	x	x	Set
17,0	3350	3075	8,30	8,30	C	B	B	74	x	x	Set
17,5	3750	3450	8,30	8,30	C	B	B	74	x	x	Set
15,5	2800	2650	9,00	9,00	D	C	A	71	x	x	
17,0	3000	2725	8,30	8,30	D	B	B	74	x	x	
17,0	3550	3250	9,30	9,30	D	B	B	74	x	x	
17,5	3150	2900	9,00	9,00	D	B	B	74	x	x	
16,5	3750	3450	8,30	8,30	C	C	B	75	x	x	
16,5	3750	3450	8,30	8,30	C	C	B	72	x	x	
16,5	4250		8,30		C	C	B	72	x	x	
17,0	4250		9,00		D	B	B	74	x	x	

Set = Reifen + Schlauch



Windpower WTL 32



Windpower WTR 69

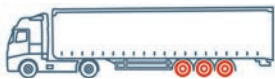

Trailer

Artikel-Nr.	Größe	Last-/Speed Index standard	optional	TL/ TT	Profil	empfohlene Felge	Außen Ø in mm	Breite in mm
104.66.745	385/65 R 22.5	160 K	158 L	TL	WTR 69	11.75	1069	384
104.66.744	385/65 R 22.5	164 K	158 L	TL	WTR 69 + (verstärkt)	11.75	1069	384
104.66.736	385/65 R 22.5	160 K	158 L	TL	WGC 28	11.75	1070	387
104.66.685	425/65 R 22.5	165 K		TL	WTR 69	13.00	1119	421
104.66.681	425/65 R 22.5	165 K		TL	WGC 28	13.00	1121	421
104.66.693	445/65 R 22.5	169 K		TL	WTR 69	14.00	1147	443
104.66.698	445/65 R 22.5	169 K		TL	WGC 28	14.00	1148	450
104.68.192	12.00 R 24	160/157 K		TT	WGC 52	8.50	1224	314

RE-Power (runderneuert)

Artikel-Nr.	Größe	Last-/Speed-Index	TL/ TT	Profil	empfohlene Felge	Außen Ø in mm	Breite in mm
199.68.062	315/70 R 22.5	152/148 M	TL	RE Power WP Alltrac	9.00	1028	314
199.68.064	315/80 R 22.5	156/150 M	TL	RE Power WP Alltrac	9.00	1092	314
199.68.076	385/65 R 22.5	160 K	TL	RE Power WP Truck	11.75	1068	385



Windpower WGC 28

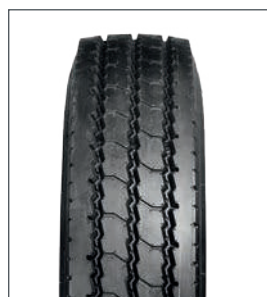

Windpower WGC 52



Windpower WTR 69
WTR 69+

WINDPOWER REIFEN

Informationen zum EU-Reifenlabel erhalten Sie auf den Seiten 14 und 15.

Profiltiefe in mm	Tragfähigkeit (kg)		Luftdruck (bar)		Rollwider- stand	Nass- haftung	Rollgeräusch		M+S	3 PMSF	Bemerkung
	Einzel	Zwilling	Einzel	Zwilling			Level	dB			
16,8	4500		9,00		C	C	B	72	x	x	
16,8	5000		9,00		B	C	B	72	x	x	
16,8	4500		9,00		C	C	B	74	x	x	
16,5	5150		8,30		C	D	A	71	x	x	
16,5	5150		8,30		C	C	B	74	x	x	
16,5	5800		8,30		C	B	B	73	x	x	
16,5	5800		8,30		C	C	B	74	x	x	
17,5	4500	4125	9,00	9,00	C	B	B	74	x	x	Set

Set = Reifen + Schlauch

Profiltiefe in mm	Tragfähigkeit (kg)		Luftdruck (bar)		M+S	3 PMSF
	Einzel	Zwilling	Einzel	Zwilling		
20,0	3550	3150	9,00	9,00	x	x
20,0	4000	3350	8,50	8,50	x	x
16,0	4900	-	9,00	-	x	x



Windpower RE Power
WP Alltrac



Windpower RE Power
WP Truck

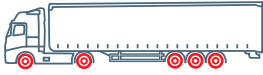

All-Position



TL/
TT



Artikel-Nr.	Größe	Last-Speed Index standard optional	TL/ TT	Profil	empfohlene Felge	Außen Ø in mm	Breite in mm
104.66.388	7.50 R 16	122/118 L	TT	WGC 08	6.00	807	214
104.66.387	8.25 R 16	126/122 L	TT	WGC 08	6.50	850	228
104.66.409	215/75 R 17.5	135/133 J	TL	WGC 28	6.00	766	218
104.66.421	235/75 R 17.5	143/141 J	TL	WGC 28	6.75	804	236
104.66.429	245/70 R 17.5	143/141 J 144/144 F	TL	WGC 28	7.50	793	252
104.66.434	265/70 R 19.5	143/141 J	TL	WGC 28	7.50	877	258
104.68.078	8.25 R 20	136/134 K	TT	WGC 08	6.50	967	232
104.68.093	9.00 R 20	144/142 K	TT	WGC 08	7.00	1025	256
104.68.107	10.00 R 20	149/146 K	TT	WGC 08	7.50	1055	273
104.68.154	11.00 R 20	150/147 K	TT	WGC 08	8.00	1087	287
104.68.182	12.00 R 20	154/151 K	TT	WGC 08	8.50	1123	310
104.66.509	10 R 22.5	144/142 L	TL	WGC 08	7.50	1022	252
104.66.515	11 R 22.5	146/143 L 148/145 K	TL	WGC 08	8.25	1054	281
104.66.527	12 R 22.5	152/149 L	TL	WGC 08	9.00	1076	303
104.66.607	275/70 R 22.5	148/145 M	TL	WGC 28	8.25	969	274
104.66.762	315/80 R 22.5	154/151 L 156/150 K	TL	WGC 52	9.00	1082	318
104.66.760	315/80 R 22.5	154/151 L 156/150 K	TL	WGC 08	9.00	1083	316
104.66.591	385/55 R 22.5	158 L 160 K	TL	WGC 28	12.25	1005	384
104.66.736	385/65 R 22.5	160 K 158 L	TL	WGC 28	11.75	1070	387
104.66.681	425/65 R 22.5	165 K	TL	WGC 28	13.00	1121	421
104.66.698	445/65 R 22.5	169 K	TL	WGC 28	14.00	1148	450
104.68.192	12.00 R 24	160/157 K	TT	WGC 52	8.50	1224	314



Windpower WGC 08











Windpower WGC 28



Windpower WGC 52

Informationen zum EU-Reifenlabel
erhalten Sie auf den Seiten 14 und 15.

 Profiltiefe in mm	 Tragfähigkeit (kg)		 Luftdruck (bar)		 Rollwider- stand	 Nass- haftung	 Rollgeräusch	Level dB	M+S	 3 PMSF	 Bemerkung
	Einzel	Zwilling	Einzel	Zwilling							
13,0	1500	1320	7,70	7,70	E	B	B	73	x	x	Set
13,0	1700	1500	6,70	6,70	D	C	B	72	x	x	
15,5	2180	2060	8,30	8,30	E	C	B	73	x	x	
16,5	2725	2575	9,00	9,00	E	B	B	74	x	x	
16,5	2725	2575	9,00	9,00	E	B	B	74	x	x	
17,5	2725	2575	8,30	8,30	E	B	B	74	x	x	
14,5	2240	2120	8,30	8,30	D	B	B	73	x	x	Set
15,5	2800	2650	9,00	9,00	D	B	B	74	x	x	Set
16,5	3250	3000	9,30	9,30	D	B	B	74	x	x	Set
17,0	3350	3075	8,30	8,30	C	B	B	74	x	x	Set
17,5	3750	3450	8,30	8,30	C	B	B	74	x	x	Set
15,5	2800	2650	9,00	9,00	D	C	A	71	x	x	
17,0	3000	2725	8,30	8,30	D	B	B	74	x	x	
17,0	3550	3250	9,30	9,30	D	B	B	74	x	x	
17,5	3150	2900	9,00	9,00	D	B	B	74	x	x	
16,5	3750	3450	8,30	8,30	C	C	B	75	x	x	
16,5	3750	3450	8,30	8,30	C	C	B	72	x	x	
17,0	4250		9,00		D	B	B	74	x	x	
16,8	4500		9,00		C	C	B	74	x	x	
16,5	5150		8,30		C	C	B	74	x	x	
16,5	5800		8,30		C	C	B	74	x	x	
17,5	4500	4125	9,00	9,00	C	B	B	74	x	x	Set

Set = Reifen + Schlauch

WINDPOWER

Get Your Job Done

WINDPOWER IM EINSATZ

BLACKPOWER SETZT AUF WINDPOWER

Effizienz liegt der Crew von Blackpower im Blut. Mit der STG Sitzler GmbH baut das Schwarzwälder Unternehmen auch bei der Speditionswahl voll auf Zuverlässigkeit und Wirtschaftlichkeit. Täglich bringen daher Sitzler-Tankzüge die mit Blackpower-Enzymen vermengten Kraftstoffe zu den Blackpower-Kunden.





„Wir können bis zu 350 kg pro Ladung mehr tanken als mit herkömmlichen Stahlfelgen. Das sind je nach Inhalt bis zu 500 Liter mehr pro Ladung - klingt wenig, ist aber doch jede 130ste Fahrt, die wir uns sparen“, rechnet Sitzler. „Außerdem ist der Pflegeaufwand deutlich geringer und nach einem Jahr in Benutzung sehen die Felgen noch aus wie neu. Das wertet unsere Fahrzeuge optisch für einen langen Zeitraum auf, ohne dass wir viel dafür tun müssen.“

Auf seinen Touren bewährt haben sich laut Spediteur Sitzler drei Produkte aus dem Bohnenkamp-Sortiment. Der Windpower-Trailerreifen WTR 69 glänzt mit seiner extrem guten Performance und hohen Laufleistung, der verlässliche Windpower-Winterreifen WSW 80 überzeugt auf der Lenkachse - und beide laufen auf den pflegeleichten Aluminiumfelgen von Accuride Wheels.

Kein Wunder, wurden die Reifen mit der modernen Lamellenkonstruktion und breitem Profilbett doch für genau solche Einsätze entwickelt und konstruiert. Mit dem 3PMSF-Symbol gekennzeichnet, entspricht der Winterreifen den neuesten Anforderungen der Straßenverkehrsordnung und ist sogar vollständig De-minimis förderfähig.

Ein Hingucker sind die schwarz-weißen Tanklastzüge der Blackpower GmbH mit ihren strahlenden Felgen vor der Schwarzwaldkulisse in jedem Fall.



„Wir haben mit dem Winterreifen WSW 80 super Erfahrungen gemacht - den fahren wir zukünftig auf all unseren Fahrzeugen auf der Lenkachse. Auch auf den teils rutschigen Straßen auf dem Weg nach Österreich hat sich der Reifen einfach bewährt“, resümiert Sitzler.





SAILUN

TYRE



SAILUN REIFEN



SERVICE-PLUS BY BOHNENKAMP

Erhalten Sie direkten Zugriff
auf unseren Online-Shop



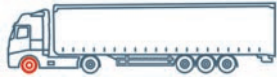

Vorderachse



TL/
TT



Artikel-Nr.	Größe	Last-/Speed Index standard optional	TT/TL	Profil	empfohlene Felge	Außen Ø in mm	Breite in mm	
110.66.102	205/75 R 17.5	124/122 M	TL	SAR1	6.00	753	205	
110.66.113	215/75 R 17.5	126/124 M	TL	SAR1	6.00	767	215	
110.66.114	215/75 R 17.5	135/133 L	TL	SAR1	6.00	767	215	
110.66.117	225/75 R 17.5	129/127 M	TL	SAR1	6.75	783	225	
110.66.122	235/75 R 17.5	143/141 L	TL	SAR1	6.75	797	235	
110.66.134	245/70 R 17.5	136/134 L	TL	SAR1	7.50	789	245	
110.66.136	245/70 R 17.5	143/141 J	146/146 F	TL	SAR1	7.50	789	245
110.66.171	225/70 R 19.5	128/126 L	TL	SAR1	6.75	811	225	
110.66.182	245/70 R 19.5	136/134 M	TL	SAR1	7.50	839	245	
110.66.195	265/70 R 19.5	140/138 M	TL	SAR1	7.50	867	265	
110.66.196	265/70 R 19.5	143/141 J	TL	SAR1	7.50	867	265	
110.66.203	285/70 R 19.5	150/148 K	TL	SAR1	8.25	895	285	
110.66.280	11 R 22.5	148/145 M	TL	S629	8.25	1054	279	
110.66.301	255/70 R 22.5	140/137 M	TL	SAR1	7.50	930	255	
110.66.312	275/70 R 22.5	148/145 M	TL	SAR1	8.25	958	275	
110.66.315	295/60 R 22.5	150/147 M	TL	S629	9.00	926	295	
110.66.329	295/80 R 22.5	152/148 M	TL	SAW1	9.00	1044	295	
110.66.338	315/60 R 22.5	152/148 M	TL	S629	9.75	950	315	
110.66.348	315/70 R 22.5	156/150 L	TL	SFR1	9.00	1014	312	
110.66.346	315/70 R 22.5	154/150 L	152/148 M	TL	SAW1	9.00	1014	315
110.66.356	315/80 R 22.5	156/150 L	154/150 M	TL	SFR1	9.00	1076	312
110.66.352	315/80 R 22.5	156/150 L	154/150 M	TL	SAW1	9.00	1076	315
110.66.374	385/55 R 22.5	160 K	158 L	TL	SAW1	12.25	996	385
110.66.370	385/55 R 22.5	160 K	158 L	TL	SFR1	12.25	996	386
110.66.381	385/65 R 22.5	160 K	158 L	TL	SFR1	11.75	1072	389
110.66.388	385/65 R 22.5	160 K	158 L	TL	SAW1	11.75	1072	385



Sailun SAR1



Sailun SAW1



Sailun SFR1



Sailun S629

Informationen zum EU-Reifenlabel
erhalten Sie auf den Seiten 14 und 15.

								 		
								Einzel	Zwilling	Einzel
Profiltiefe in mm	Tragfähigkeit (kg)		Luftdruck (bar)		Rollwider- stand	Nass- haftung	Rollgeräusch			
13,0	1600	1500	7,50	7,50	D	B	B	73	x	x
12,5	1700	1600	7,00	7,00	D	B	B	73	x	x
12,5	2180	2060	8,60	8,60	D	B	B	73	x	x
12,5	1850	1750	7,25	7,25	D	B	B	73	x	x
13,0	2725	2575	8,60	8,60	D	B	B	73	x	x
13,0	2240	2120	8,50	8,50	D	B	B	73	x	x
13,0	2725	2575	8,75	8,75	D	B	B	73	x	x
12,5	1800	1700	7,60	7,60	D	B	B	73	x	x
13,0	2240	2120	8,25	8,25	D	B	B	73	x	x
13,5	2500	2360	7,75	7,75	D	C	B	73	x	x
13,5	2725	2575	9,00	9,00	D	C	B	73	x	x
13,0	3350	3150	9,00	9,00	D	C	B	72	x	x
15,5	3150	2900	8,50	8,50	D	C	B	73	x	x
13,5	2500	2300	8,00	8,00	D	C	B	73	x	x
14,5	3150	2900	9,00	9,00	C	C	A	71	x	x
14,5	3350	3075	9,00	9,00	C	B	B	73	x	x
16,5	3550	3150	8,50	8,50	E	C	B	74	x	x
14,5	3550	3150	9,00	9,00	C	B	B	73	x	x
15,5	4000	3350	9,00	9,00	C	B	B	73	x	x
16,0	3750	3350	9,00	9,00	E	C	B	74	x	x
16,0	4000	3350	8,50	8,50	C	B	B	73	x	x
20,5	4000	3350	8,50	8,50	E	C	B	74	x	x
14,5	4500		9,00		E	C	B	74	x	x
14,5	4500		9,00		C	C	B	73	x	x
14,5	4500		9,00		C	C	B	73	x	x
15,0	4500		9,00		E	C	B	74	x	x

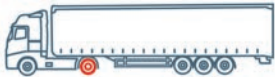

Antriebsachse



TL/
TT



Artikel-Nr.	Größe	Last-/Speed Index standard optional	TL/ TT	Profil	empfohlene Felge	Außen Ø in mm	Breite in mm
110.66.101	205/75 R 17.5	124/122 L	TL	SDR1	6.00	753	205
110.66.112	215/75 R 17.5	126/124 M	TL	SDR1	6.00	767	211
110.66.118	225/75 R 17.5	129/127 M	TL	SDR1	6.75	783	225
110.66.121	235/75 R 17.5	143/141 K	TL	SDR1	6.75	797	233
110.66.133	245/70 R 17.5	143/141 J 146/146 F	TL	SDR1	7.50	789	248
110.66.181	245/70 R 19.5	136/134 M	TL	SDR1	7.50	839	248
110.66.193	265/70 R 19.5	143/141 J	TL	SDR1	7.50	867	262
110.66.197	265/70 R 19.5	143/141 J	TL	STM1	7.50	867	265
110.66.204	285/70 R 19.5	146/144 M	TL	SDR1	8.25	895	283
110.66.282	11 R 22.5	148/145 L	TL	SDR1	8.25	1065	279
110.66.290	13 R 22.5	156/150 K	TL	S711	9.75	1136	320
110.66.296	13 R 22.5	156/150 G	TL	SD01	9.75	1136	330
110.66.316	295/60 R 22.5	150/147 L	TL	S701	9.00	926	295
110.66.317	295/60 R 22.5	150/147 L	TL	S702	9.00	926	295
110.66.321	295/80 R 22.5	152/148 J	TL	SD01	9.00	1044	295
110.66.323	295/80 R 22.5	152/148 M	TL	SDL1	9.00	1044	298
110.66.324	295/80 R 22.5	152/148 M	TL	SDR1	9.00	1044	298
110.66.322	295/80 R 22.5	152/149 L	TL	SDW1	9.00	1044	295
110.66.336	315/60 R 22.5	152/148 L	TL	S702	9.75	950	315
110.66.337	315/60 R 22.5	152/148 L	TL	S701	9.75	950	315
110.66.340	315/70 R 22.5	154/150 L 152/148 M	TL	SDL1	9.00	1014	312
110.66.341	315/70 R 22.5	154/150 L 152/148 M	TL	SDR1	9.00	1014	312
110.66.345	315/70 R 22.5	154/150 L 152/148 M	TL	SDW1	9.00	1014	315
110.66.339	315/80 R 22.5	156/153 K	TL	S913A	9.00	1076	315
110.66.347	315/80 R 22.5	156/150 G 154/150 J	TL	SD01	9.00	1082	315



Sailun SD01



Sailun SDL1



Sailun SDR1



Sailun SDW1



Sailun STM1

Informationen zum EU-Reifenlabel erhalten Sie auf den Seiten 14 und 15.

Profiltiefe in mm	Tragfähigkeit (kg)		Luftdruck (bar)		Rollwider- stand	Nass- haftung	Rollgeräusch Level	dB	M+S	3 PMSF
	Einzel	Zwilling	Einzel	Zwilling						
15,0	1600	1500	7,50	7,50	E	B	A	73	x	x
15,0	1700	1600	7,00	7,00	E	B	A	73	x	x
15,0	1850	1750	7,25	7,25	E	B	A	73	x	x
15,0	2725	2575	8,60	8,60	E	B	A	73	x	x
15,5	2725	2575	8,75	8,75	E	B	B	74	x	x
15,5	2240	2120	8,25	8,25	E	B	B	74	x	x
15,5	2725	2575	9,00	9,00	E	B	B	74	x	x
16,0	2725	2575	9,00	9,00	D	C	B	75	x	x
16,0	3000	2800	9,00	9,00	E	B	B	74	x	x
19,5	3150	2900	8,50	8,50	E	C	B	75	x	x
20,0	4000	3350	8,75	8,75	D	C	B	76	x	x
23,5	4000	3350	8,75	8,75	POR*				x	x
17,0	3350	3075	9,00	9,00	D	C	B	75	x	x
19,0	3350	3075	9,00	9,00	E	C	B	75	x	x
23,5	3550	3150	8,50	8,50	POR*				x	x
17,0	3550	3150	8,50	8,50	D	C	B	75	x	x
22,0	3550	3150	8,50	8,50	E	C	B	75	x	x
20,5	3550	3250	9,00	9,00	D	C	A	73	x	x
20,0	3550	3150	9,00	9,00	E	C	B	75	x	x
18,0	3550	3150	9,00	9,00	D	C	B	75	x	x
18,0	3750	3350	9,00	9,00	D	C	B	75	x	x
20,0	3750	3350	9,00	9,00	E	C	B	75	x	x
20,5	3750	3350	9,00	9,00	D	C	A	73	x	x
21,5	4000	3650	8,50	8,50	POR*				x	x
23,5	4000	3350	8,50	8,50	POR*				x	x

* POR = Professional Off Road (keine Labelwerte nötig)

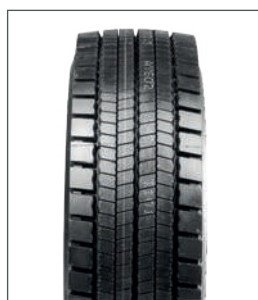

Sailun S701



Sailun S702



Sailun S711



Sailun S913A

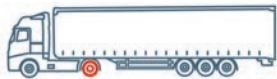

Antriebsachse

Artikel-Nr.	Größe	Last-/Speed Index standard	optional	TL/ TT	Profil	empfohlene Felge	Außen Ø in mm	Breite in mm
110.66.350	315/80 R 22.5	156/150 K	158/156 G	TL	S711	9.00	1082	312
110.66.354	315/80 R 22.5	156/150 L	154/150 M	TL	SDL1	9.00	1076	312
110.66.355	315/80 R 22.5	156/150 L	154/150 M	TL	SDR1	9.00	1076	312
110.66.353	315/80 R 22.5	156/150 L	154/150 M	TL	SDW1	9.00	1076	315

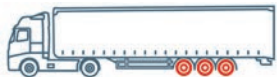

Trailer

Artikel-Nr.	Größe	Last-/Speed Index standard	optional	TL/ TT	Profil	empfohlene Felge	Außen Ø in mm	Breite in mm
110.66.102	205/75 R 17.5	124/122 M		TL	SAR1	6.00	753	205
110.66.113	215/75 R 17.5	126/124 M		TL	SAR1	6.00	767	215
110.66.114	215/75 R 17.5	135/133 L		TL	SAR1	6.00	767	215
110.66.117	225/75 R 17.5	129/127 M		TL	SAR1	6.75	783	225
110.66.122	235/75 R 17.5	143/141 L		TL	SAR1	6.75	797	235
110.66.134	245/70 R 17.5	136/134 L		TL	SAR1	7.50	789	245
110.66.136	245/70 R 17.5	143/141 J	146/146 F	TL	SAR1	7.50	789	245
110.66.171	225/70 R 19.5	128/126 L		TL	SAR1	6.75	811	225
110.66.182	245/70 R 19.5	136/134 M		TL	SAR1	7.50	839	245
110.66.195	265/70 R 19.5	140/138 M		TL	SAR1	7.50	867	265
110.66.196	265/70 R 19.5	143/141 J		TL	SAR1	7.50	867	265



Sailun SAR1

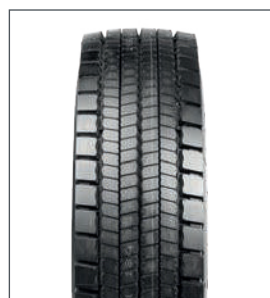

Sailun SDL1

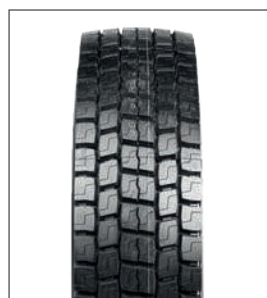

Sailun SDR1

Informationen zum EU-Reifenlabel erhalten Sie auf den Seiten 14 und 15.

Profiltiefe in mm		Tragfähigkeit (kg) Einzel Zwilling		Luftdruck (bar) Einzel Zwilling		Rollwiderstand	Nasshaftung	Rollgeräusch Level dB	M+S	3 PMSF
20,5	4000	3350	8,50	8,50	D	C	B	75	x	x
18,0	4000	3350	8,50	8,50	D	C	B	75	x	x
22,5	4000	3350	8,50	8,50	E	C	B	75	x	x
16,5	4000	3350	8,50	8,50	D	C	A	73	x	x

Profiltiefe in mm		Tragfähigkeit (kg) Einzel Zwilling		Luftdruck (bar) Einzel Zwilling		Rollwiderstand	Nasshaftung	Rollgeräusch Level dB	M+S	3 PMSF
13,0	1600	1500	7,50	7,50	D	B	B	73	x	x
12,5	1700	1600	7,00	7,00	D	B	B	73	x	x
12,5	2180	2060	8,60	8,60	D	B	B	73	x	x
12,5	1850	1750	7,25	7,25	D	B	B	73	x	x
13,0	2725	2575	8,60	8,60	D	B	B	73	x	x
13,0	2240	2120	8,50	8,50	D	B	B	73	x	x
13,0	2725	2575	8,75	8,75	D	B	B	73	x	x
12,5	1800	1700	7,60	7,60	D	B	B	73	x	x
13,0	2240	2120	8,25	8,25	D	B	B	73	x	x
13,5	2500	2360	7,75	7,75	D	C	B	73	x	x
13,5	2725	2575	9,00	9,00	D	C	B	73	x	x



Sailun SDW1



Sailun S711

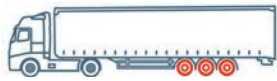

Trailer



Artikel-Nr.	Größe	Last-/Speed Index standard optional	TL/ TT	Profil	empfohlene Felge	Außen Ø in mm	Breite in mm	
110.66.197	265/70 R 19.5	143/141 J	TL	STM1	7.50	867	265	
110.66.203	285/70 R 19.5	150/148 K	TL	SAR1	8.25	895	285	
110.66.202	285/70 R 19.5	146/144 L	144/142 M	SFR1	8.25	895	283	
110.66.241	435/50 R 19.5	160 J	TL	STL1	14.00	931	438	
110.66.251	445/45 R 19.5	160 J	TL	STL1	15.00	895	446	
110.66.301	255/70 R 22.5	140/137 M	TL	SAR1	7.50	930	255	
110.66.312	275/70 R 22.5	148/145 M	TL	SAR1	8.25	958	275	
110.66.325	295/80 R 22.5	154/149 M	TL	SFR1	9.00	1044	298	
110.66.329	295/80 R 22.5	152/148 M	TL	SAW1	9.00	1044	295	
110.66.348	315/70 R 22.5	156/150 L	TL	SFR1	9.00	1014	312	
110.66.346	315/70 R 22.5	156/150 L	TL	SAW1	9.00	1014	315	
110.66.356	315/80 R 22.5	156/150 L	154/150 M	SFR1	9.00	1076	312	
110.66.352	315/80 R 22.5	156/150 L	154/150 M	SAW1	9.00	1076	315	
110.66.369	385/55 R 22.5	160 K	158 L	TL	STR1+	12.25	996	385
110.66.374	385/55 R 22.5	160 K	158 L	TL	SAW1	12.25	996	385
110.66.370	385/55 R 22.5	160 K	158 L	TL	SFR1	12.25	996	386
110.66.371	385/55 R 22.5	160 K	158 L	TL	STL1	12.25	996	386
110.66.376	385/65 R 22.5	160 K	158 L	TL	STR1+	11.75	1072	385
110.66.377	385/65 R 22.5	164 K	158 L	TL	STR1+	11.75	1072	385
110.66.383	385/65 R 22.5	160 K	158 L	TL	STL1	11.75	1072	389
110.66.381	385/65 R 22.5	160 K	158 L	TL	SFR1	11.75	1072	389
110.66.388	385/65 R 22.5	160 K	158 L	TL	SAW1	11.75	1072	385
110.66.384	385/65 R 22.5	164 K	158 L	TL	STL1	11.75	1072	389



Sailun SAR1



Sailun SAW1



Sailun SFR1



Sailun STL1

Informationen zum EU-Reifenlabel erhalten Sie auf den Seiten 14 und 15.

Profiltiefe in mm	Tragfähigkeit (kg)		Luftdruck (bar)		Rollwider- stand	Nass- haftung	Rollgeräusch Level	dB	M+S	3 PMSF
	Einzel	Zwilling	Einzel	Zwilling					M+S	
16,0	2725	2575	9,00	9,00	D	C	B	75	x	x
13,0	3350	3150	9,00	9,00	D	C	B	72	x	x
13,0	3000	2800	9,00	9,00	C	C	B	73	x	x
12,5	4500		9,00		B	C	B	72	x	x
12,5	4500		9,00		B	C	B	72	x	x
13,5	2500	2300	8,00	8,00	D	C	B	73	x	x
14,5	3150	2900	9,00	9,00	C	C	A	71	x	x
16,0	3750	3250	9,00	9,00	C	B	B	73	x	x
16,5	3550	3150	8,50	8,50	E	C	B	74	x	x
15,5	4000	3350	9,00	9,00	C	B	B	73	x	x
16,0	4000	3350	9,00	9,00	E	C	B	74	x	x
16,0	4000	3350	8,50	8,50	C	B	B	73	x	x
20,5	4000	3350	8,50	8,50	E	C	B	74	x	x
15,0	4500		9,00		C	B	B	72	x	x
14,5	4500		9,00		E	C	B	74	x	x
14,5	4500		9,00		C	C	B	73	x	x
12,5	4500		9,00		B	B	B	72	x	x
16,0	4500		9,00		C	C	B	72	x	x
16,0	5000		9,00		C	C	B	72	x	x
13,0	4500		9,00		B	B	A	71	x	x
14,5	4500		9,00		C	C	B	73	x	x
15,0	4500		9,00		E	C	B	74	x	x
13,0	5000		9,00		B	B	A	71	x	x



Sailun STM1



Sailun STR1 +



All-Position

Artikel-Nr.	Größe	Last-/Speed Index standard	optional	TL/ TT	Profil	empfohlene Felge	Außen Ø in mm	Breite in mm
110.66.284	11 R 22.5	148/145 L		TL	S815	8.25	1054	279
110.66.294	13 R 22.5	156/150 L		TL	S815	9.75	1124	330
110.66.314	295/80 R 22.5	152/148 M		TL	S815	9.00	1044	295
110.66.349	315/80 R 22.5	156/150 L		TL	S815	9.00	1076	315
110.66.375	385/65 R 22.5	160 K	158 L	TL	S825	11.75	1072	385
110.66.389	385/65 R 22.5	160 K	158 L	TL	STM1	11.75	1072	385
110.66.406	425/65 R 22.5	165 K		TL	S825	12.25	1124	425
110.66.411	445/65 R 22.5	168 K		TL	S825	13.00	1150	444



Bus

Artikel-Nr.	Größe	Last-/Speed Index standard	optional	TL/ TT	Profil	empfohlene Felge	Außen Ø in mm	Breite in mm
110.66.313	275/70 R 22.5	148/145 J	152/148 F	TL	CITYCONVOY	8.25	958	275
110.66.330	295/80 R 22.5	152/149 K		TL	CITYCONVOY	9.00	1044	295



Sailun S815

















Sailun S825



Sailun STM1

Informationen zum EU-Reifenlabel erhalten Sie auf den Seiten 14 und 15.

 Profiltiefe in mm	 Tragfähigkeit (kg)		 Luftdruck (bar)		 Rollwider- stand	 Nass- haftung	 Rollgeräusch Level	dB		
	Einzel	Zwilling	Einzel	Zwilling					M+S	3 PMSF
18,0	3150	2900	8,50	8,50	D	C	B	73	x	x
17,5	4000	3350	8,75	8,75	D	C	B	73	x	x
17,0	3550	3150	8,50	8,50	D	C	B	73	x	x
17,0	4000	3350	8,50	8,50	D	C	B	73	x	x
16,5	4500		9,00		D	B	B	72	x	x
17,3	4500		9,00		D	C	A	72	x	x
17,5	5150		8,30		D	C	B	72	x	x
16,5	5600		8,30		D	C	B	72	x	x

 Profiltiefe in mm	 Tragfähigkeit (kg)		 Luftdruck (bar)		 Rollwider- stand	 Nass- haftung	 Rollgeräusch Level	dB		
	Einzel	Zwilling	Einzel	Zwilling					M+S	3 PMSF
20,5	3150	2900	9,00	9,00	D	C	B	72	x	x
17,5	3550	3250	9,00	9,00	D	C	B	72	x	x



Sailun CITYCONVOY

SAILUN
Reifen

BOKA



BOKA REIFEN



SERVICE-PLUS BY BOHNENKAMP

Erhalten Sie direkten Zugriff
auf unseren Online-Shop



LKW Reifen diagonal

Artikel-Nr.	Größe	PR	Last-/ Speed-Index	TL/ TT	Profil	Fabrikat	empfohlene Felge	Außen Ø in mm	Breite in mm
199.66.299	7.50 - 15	12	119/115 K	TT	Boka Truck	Rib (Straße)	6.00	780	215
199.66.296	6.00 - 16	10	102/98 K	TT	Boka Truck	Rib (Straße)	4.00	740	160
199.66.297	6.00 - 16	10	102/98 K	TT	Boka Truck	Lug (Gelände)	4.00	740	160
199.66.298	6.50 - 16	12	110/105 K	TT	Boka Truck	Rib (Straße)	5.50	755	182
199.66.301	7.00 - 16	14	118/114 K	TT	Boka Truck	Rib (Straße)	5.50	775	200
199.66.300	7.50 - 16	14	122/118 K	TT	Boka Truck	Rib (Straße)	5.50	808	220
199.66.302	8.25 - 16	14	126/122 K	TT	Boka Truck	Lug (Gelände)	6.50	856	237
199.66.303	8.25 - 16	14	126/122 K	TT	Boka Truck	Rib (Straße)	6.50	856	237
199.66.304	7.00 - 20	14	127/123 G	TT	Boka Truck	Rib (Straße)	5.50	904	200
199.66.306	7.50 - 20	14	130/126 G	TT	Boka Truck	Rib (Straße)	6.00	910	190
199.66.309	8.25 - 20	14	135/131 G	TT	Boka Truck	Rib (Straße)	6.50	970	234
199.66.311	9.00 - 20	14	141/136 G	TT	Boka Truck	Lug (Gelände)	7.00	1059	280
199.66.312	9.00 - 20	14	141/136 G	TT	Boka Truck	Rib (Straße)	7.00	1012	256
199.66.313	10.00 - 20	16	146/142 G	TT	Boka Truck	Lug (Gelände)	7.50	1054	278
199.66.314	10.00 - 20	16	146/142 G	TT	Boka Truck	Rib (Straße)	7.50	1062	278
199.66.315	11.00 - 20	16	149/144 G	TT	Boka Truck	Lug (Gelände)	8.00	1128	316
199.66.316	11.00 - 20	16	149/144 G	TT	Boka Truck	Rib (Straße)	8.00	1080	291
199.66.317	12.00 - 20	18	154/149 G	TT	Boka Truck	Lug (Gelände)	8.50	1170	340
199.66.318	12.00 - 20	18	154/149 G	TT	Boka Truck	Rib (Straße)	8.50	1120	312







Boka LUG (Gelände)



Boka RIB (Straße)

Informationen zum EU-Reifenlabel
erhalten Sie auf den Seiten 14 und 15.

 Profiltiefe in mm	 Tragfähigkeit (kg)		 Luftdruck (bar)		 Bemerkung	 Ventil
	Einzel	Zwilling	Einzel	Zwilling		
11,0	1360	1215	6,30	6,30	inkl. Schlauch+WB	TR77 A
8,0	850	750	5,30	5,30	inkl. Schlauch+WB	TR77 A
8,0	850	750	5,30	5,30	inkl. Schlauch	TR77 A
10,0	1060	925	6,30	6,30	inkl. Schlauch+WB	TR77 A
8,0	1320	1180	7,30	7,30	inkl. Schlauch+WB	TR75 A
10,0	1500	1320	7,30	7,30	inkl. Schlauch+WB	TR77 A
11,0	1700	1500	6,30	6,30	inkl. Schlauch+WB	TR77 A
9,0	1700	1500	6,30	6,30	inkl. Schlauch+WB	TR77 A
12,0	1750	1550	8,40	7,70	inkl. Schlauch+WB	TR175 A
13,0	1900	1700	8,10	7,40	inkl. Schlauch+WB	TR175 A
13,0	2180	1950	8,10	7,40	inkl. Schlauch+WB	TR175 A
14,0	2575	2240	7,70	7,00	inkl. Schlauch+WB	TR175 A
14,0	2575	2240	7,70	7,00	inkl. Schlauch+WB	TR175 A
13,0	3000	2650	8,10	7,40	inkl. Schlauch+WB	TR175 A
13,0	3000	2650	8,10	7,40	inkl. Schlauch+WB	TR175 A
16,0	3250	2800	8,10	7,40	inkl. Schlauch+WB	TR175 A
16,0	3250	2800	8,10	7,40	inkl. Schlauch+WB	TR175 A
18,0	3750	3250	8,10	7,40	inkl. Schlauch+WB	TR175 A
18,0	3750	3250	8,10	7,40	inkl. Schlauch+WB	TR175 A

LKW Reifen diagonal







Artikel-Nr.	Größe	PR	Last-/ Speed-Index	TT/TL	Profil	Fabrikat	empfohlene Felge	Außen Ø in mm	Breite in mm
199.66.335	7.50 - 16	14	122 D	TT	Boka Agrar Trans	BTG208 (Straße)	6.00	785	202
199.66.330	8.25 - 16	14	126 D	TT	Boka Agrar Trans	BTG208 (Straße)	6.50	832	229
199.66.340	7.00 - 20	14	127 D	TT	Boka Agrar Trans	BTG208 (Straße)	5.50	898	203
199.66.345	7.50 - 20	14	130 D	TT	Boka Agrar Trans	BTG208 (Straße)	6.00	926	219
199.66.350	8.25 - 20	14	136 D	TT	Boka Agrar Trans	BTG208 (Straße)	6.50	974	242
199.66.355	9.00 - 20	14	141 D	TT	Boka Agrar Trans	BTG208 (Straße)	7.00	1038	259
199.66.360	10.00 - 20	16	146 D	TT	Boka Agrar Trans	BTG208 (Straße)	7.50	1030	274
199.66.365	11.00 - 20	16	149 D	TT	Boka Agrar Trans	BTG208 (Straße)	8.00	1058	301
199.66.370	12.00 - 20	18	154 D	TT	Boka Agrar Trans	BTG208 (Straße)	8.50	1126	320



Boka BTG208 (Straße)

Informationen zum EU-Reifenlabel
erhalten Sie auf den Seiten 14 und 15.

 Profiltiefe in mm	 Tragfähigkeit (kg)		 Luftdruck (bar)		 Bemerkung	 Ventil
	Einzel	Zwilling	Einzel	Zwilling		
9,5	1500		7,30		inkl. Schlauch+WB	TR77 A
11,5	1700		6,30		inkl. Schlauch+WB	TR175 A
11,5	1750		8,40		inkl. Schlauch+WB	TR78 A
12,0	1900		8,10		inkl. Schlauch+WB	TR78 A
13,0	2240		8,10		inkl. Schlauch+WB	TR78 A
13,5	2575		7,70		inkl. Schlauch+WB	TR179 A
13,5	3000		8,10		inkl. Schlauch+WB	TR179 A
14,5	3250		8,10		inkl. Schlauch+WB	TR179 A
15,0	3750		8,10		inkl. Schlauch+WB	TR179 A

 **ONYX**



ONYX LLKW REIFEN

 ONYX

SERVICE-PLUS BY BOHNENKAMP

Erhalten Sie direkten Zugriff
auf unseren Online-Shop



All Season









Artikel-Nr.	Größe	Last-/ Speed-Index	TT/ TL	Profil	empfohlene Felge	Außen Ø in mm	Breite in mm
101.65.205	215/65 R 15 C	104/102 T	TL	NY-AS 687	6.50	661	221
101.65.200	195/70 R 15 C	104/102 R	TL	NY-AS 687	6.00	655	201
101.65.210	215/70 R 15 C	109/107 R	TL	NY-AS 687	6.50	683	221
101.65.215	225/70 R 15 C	112/110 R	TL	NY-AS 687	6.50	697	228
101.65.220	195/60 R 16 C	99/97 T	TL	NY-AS 687	6.00	640	201
101.65.240	215/60 R 16 C	108/106 T	TL	NY-AS 687	6.50	664	221
101.65.225	195/65 R 16 C	104/102 R	TL	NY-AS 687	6.00	660	201
101.65.235	205/65 R 16 C	107/105 T	TL	NY-AS 687	6.00	672	209
101.65.237	205/75 R 16 C	113/111 R	TL	NY-AS 687	5.50	714	203
101.65.245	215/65 R 16 C	109/107 T	TL	NY-AS 687	6.50	686	221
101.65.255	225/65 R 16 C	112/110 R	TL	NY-AS 687	6.50	698	228
101.65.265	235/65 R 16 C	115/113 T	TL	NY-AS 687	7.00	712	240
101.65.230	195/75 R 16 C	107/105 R	TL	NY-AS 687	5.50	698	196
101.65.250	215/75 R 16 C	116/114 R	TL	NY-AS 687	6.00	728	216
101.65.260	225/75 R 16 C	121/120 R	TL	NY-AS 687	6.00	744	223









Winter

Artikel-Nr.	Größe	Last-/ Speed-Index	TT/ TL	Profil	empfohlene Felge	Außen Ø in mm	Breite in mm
101.65.090	215/65 R 15 C	104/102 R	TL	NY-W287	6.50	661	221
101.65.100	195/70 R 15 C	104/102 R	TL	NY-W287	6.00	655	201
101.65.105	215/70 R 15 C	109/107 R	TL	NY-W287	6.50	683	221
101.65.110	225/70 R 15 C	112/110 R	TL	NY-W287	6.50	697	228
101.65.115	195/60 R 16 C	99/97 T	TL	NY-W287	6.00	640	201
101.65.120	215/60 R 16 C	108/106 R	TL	NY-W287	6.50	664	221
101.65.125	195/65 R 16 C	104/102 R	TL	NY-W287	6.00	660	201
101.65.130	205/65 R 16 C	107/105 R	TL	NY-W287	6.00	672	209
101.65.135	215/65 R 16 C	109/107 R	TL	NY-W287	6.50	686	221
101.65.137	225/65 R 16 C	112/110 R	TL	NY-W287	6.50	698	228
101.65.140	235/65 R 16 C	115/113 R	TL	NY-W287	7.00	712	240
101.65.150	195/75 R 16 C	107/105 R	TL	NY-W287	5.50	698	196
101.65.155	215/75 R 16 C	116/114 R	TL	NY-W287	6.00	728	216

Profilabbildungen auf der nächsten Seite

Informationen zum EU-Reifenlabel erhalten Sie auf den Seiten 14 und 15.

															
Profiltiefe in mm	Tragfähigkeit (kg)		Luftdruck (bar)		Rollwider- stand	Nass- haftung	Rollgeräusch		M+S	3 PMSF					
	Einzel	Zwilling	Einzel	Zwilling			Level	dB							
9,7	900	850	3,75	3,75	D	D	B	73	x	x					
9,7	900	850	4,50	4,50	D	D	B	73	x	x					
9,7	1030	975	4,50	4,50	D	D	B	73	x	x					
9,7	1120	1060	4,50	4,50	D	D	B	73	x	x					
9,7	775	730	3,75	3,75	D	D	B	73	x	x					
9,7	1000	950	4,75	4,75	D	D	B	73	x	x					
9,7	900	850	4,75	4,75	D	D	B	73	x	x					
9,7	975	925	4,75	4,75	D	D	B	73	x	x					
9,7	1150	1090	5,25	5,25	D	D	B	73	x	x					
9,7	1030	975	4,75	4,75	D	D	B	73	x	x					
9,7	1120	1060	4,75	4,75	D	D	B	73	x	x					
9,7	1215	1150	4,75	4,75	D	D	B	73	x	x					
9,7	975	925	4,75	4,75	D	D	B	73	x	x					
9,7	1250	1180	5,25	5,25	D	D	B	73	x	x					
9,7	1450	1400	5,75	5,75	D	D	B	73	x	x					

															
Profiltiefe in mm	Tragfähigkeit (kg)		Luftdruck (bar)		Rollwider- stand	Nass- haftung	Rollgeräusch		M+S	3 PMSF					
	Einzel	Zwilling	Einzel	Zwilling			Level	dB							
9,7	900	850	3,75	3,75	D	D	B	73	x	x					
9,7	900	850	4,50	4,50	D	D	B	73	x	x					
9,7	1030	975	4,50	4,50	D	D	B	73	x	x					
9,7	1120	1060	4,50	4,50	D	D	B	73	x	x					
9,7	775	730	3,75	3,75	D	D	B	73	x	x					
9,7	1000	950	4,75	4,75	D	D	B	73	x	x					
9,7	900	850	4,75	4,75	D	D	B	73	x	x					
9,7	975	925	4,75	4,75	D	D	B	73	x	x					
9,7	1030	975	4,75	4,75	D	D	B	73	x	x					
9,7	1120	1060	4,75	4,75	D	D	B	73	x	x					
9,7	1215	1150	4,75	4,75	D	D	B	73	x	x					
8,7	975	925	4,75	4,75	D	D	B	73	x	x					
9,7	1250	1180	5,25	5,25	D	D	B	73	x	x					



Sommer



TL/
TT



Artikel-Nr.	Größe	Last-/ Speed-Index	TT/TL	Profil	empfohlene Felge	Außen Ø in mm	Breite in mm
101.65.650	155 R 12 C	88/86 Q	TL	NY-05	4.50	550	157
101.65.320	155 R 13 C	90/88 Q	TL	NY-06	4.50	578	157
101.65.340	175 R 13 C	97/95 R	TL	NY-06	5.00	610	178
101.65.470	165/70 R 13 LT	88/86 S	TL	NY-06	5.00	562	170
101.65.360	175 R 14 C	99/98 R	TL	NY-06	5.00	634	178
101.65.700	185 R 14 C	102/100 R	TL	NY-05	5.50	650	188
101.65.710	195 R 14 C	106/104 R	TL	NY-05	5.50	666	198
101.65.390	205/65 R 15 C	102/100T	TL	NY-06	6.00	647	209
101.65.520	195/70 R 15 C	104/102 R	TL	NY-06	6.00	655	201
101.65.530	205/70 R 15 C	106/104 R	TL	NY-06	6.00	669	209
101.65.540	215/70 R 15 C	109/107 R	TL	NY-06	6.50	683	221
101.45.100	225/70 R 15 C	112/110 R	TL	NY-06	6.50	697	228
101.65.730	195 R 15 C	106/104 R	TL	NY-05	5.50	693	198
101.65.410	195/65 R 16 C	104/102T	TL	NY-06	6.00	650	201
101.65.440	225/65 R 16 C	112/110T	TL	NY-06	6.50	698	228
101.65.450	235/65 R 16 C	115/113T	TL	NY-06	7.00	712	240
101.65.590	195/75 R 16 C	107/105 R	TL	NY-06	5.50	698	196
101.65.610	215/75 R 16 C	116/114 R	TL	NY-06	6.00	728	216

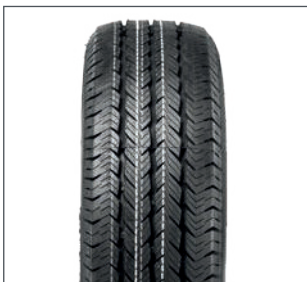

Onyx NY-AS 687



Onyx NY-W287



Onyx NY-05



Onyx NY-06

Informationen zum EU-Reifenlabel erhalten Sie auf den Seiten 14 und 15.

Profiltiefe in mm	Tragfähigkeit (kg)		Luftdruck (bar)		Rollwider- stand	Nass- haftung	Rollgeräusch		M+S	3 PMSF
	Einzel	Zwilling	Einzel	Zwilling			Level	dB		
7,3	560	530	4,50	4,50	D	C	B	72	x	
7,3	600	560	4,50	4,50	D	C	B	72	x	
7,3	730	690	4,50	4,50	D	C	B	72	x	
7,3	560	530	3,75	3,75	D	C	B	72	x	
7,3	775	750	4,50	4,50	D	C	B	72	x	
8,5	850	800	4,50	4,50	D	C	B	72	x	
8,7	950	900	4,50	4,50	D	C	B	72	x	
9,7	850	800	3,75	3,75	D	C	B	72	x	
10,2	900	850	4,50	4,50	D	C	B	72	x	
10,2	950	900	4,50	4,50	D	C	B	72	x	
10,2	1030	975	4,50	4,50	D	C	B	72	x	
10,2	1120	1060	4,50	4,50	D	C	B	72	x	
8,7	950	900	4,50	4,50	D	C	B	72	x	
9,7	900	850	4,75	4,75	D	C	B	72	x	
9,7	1120	1060	4,75	4,75	D	C	B	72	x	
9,7	1215	1150	4,75	4,75	D	C	B	72	x	
8,7	975	925	4,75	4,75	D	C	B	72	x	
9,7	1250	1180	5,25	5,25	D	C	B	72	x	

 **SAILUN**
TYRE



SAILUN LLKW REIFEN



SERVICE-PLUS BY BOHNENKAMP

Erhalten Sie direkten Zugriff
auf unseren Online-Shop





All Season

Artikel-Nr.	Größe	Last-/ Speed-Index	TT/ TL	Profil	empfohlene Felge	Außen Ø in mm	Breite in mm
110.65.100	195/70 R 15 C	104/102 T	TL	Commercio 4 Seasons	6.00	655	195
110.65.105	215/70 R 15 C	109/107 S	TL	Commercio 4 Seasons	6.50	683	215
110.65.110	225/70 R 15 C	112/110 S	TL	Commercio 4 Seasons	6.50	697	225
110.65.120	195/75 R 16 C	110/108 R	TL	Commercio 4 Seasons	5.50	698	195
110.65.115	195/65 R 16 C	104/102 T	TL	Commercio 4 Seasons	6.00	660	195
110.65.125	205/65 R 16 C	107/105 T	TL	Commercio 4 Seasons	6.00	672	205
110.65.135	215/75 R 16 C	116/114 R	TL	Commercio 4 Seasons	6.00	728	215
110.65.130	215/65 R 16 C	109/107 T	TL	Commercio 4 Seasons	6.50	686	215
110.65.145	225/75 R 16 C	121/120 R	TL	Commercio 4 Seasons	6.00	744	225
110.65.140	225/65 R 16 C	112/110 T	TL	Commercio 4 Seasons	6.50	698	225
110.65.150	235/65 R 16 C	121/119 R	TL	Commercio 4 Seasons	7.00	712	235



Winter

Artikel-Nr.	Größe	Last-/ Speed-Index	TT/ TL	Profil	empfohlene Felge	Außen Ø in mm	Breite in mm
110.65.200	195/70 R 15 C	104/102 R	TL	Endure WSL1	6.00	655	195
110.65.205	215/70 R 15 C	109/107 R	TL	Endure WSL1	6.50	683	215
110.65.210	225/70 R 15 C	112/110 R	TL	Endure WSL1	6.50	697	225
110.65.215	195/75 R 16 C	107/105 R	TL	Endure WSL1	5.50	698	195
110.65.220	205/65 R 16 C	107/105 T	TL	Endure WSL1	6.00	672	205
110.65.230	215/75 R 16 C	116/114 R	TL	Endure WSL1	6.00	728	215
110.65.225	215/65 R 16 C	109/107 T	TL	Endure WSL1	6.50	686	215
110.65.235	225/65 R 16 C	112/110 R	TL	Endure WSL1	6.50	698	225
110.65.240	235/65 R 16 C	121/119 R	TL	Endure WSL1	7.00	712	235



Sailun Commercio 4 Seasons



Sailun Endure WSL1

Informationen zum EU-Reifenlabel
erhalten Sie auf den Seiten 14 und 15.

Profiltiefe in mm	Tragfähigkeit (kg)		Luftdruck (bar)		Rollwider- stand	Nass- haftung	Rollgeräusch		M+S	3 PMSF
	Einzel	Zwilling	Einzel	Zwilling			Level	dB	M+S	
9,7	900	850	4,50	4,50	D	B	B	72	x	x
9,7	1030	975	4,50	4,50	C	A	B	72	x	x
9,7	1120	1060	4,50	4,50	C	A	B	72	x	x
9,7	1060	1000	5,25	5,25	C	B	B	72	x	x
9,7	900	850	4,75	4,75	D	B	B	72	x	x
9,7	975	925	4,75	4,75	D	A	B	72	x	x
9,7	1250	1180	5,25	5,25	C	A	B	72	x	x
9,7	1030	975	4,75	4,75	D	A	B	72	x	x
9,7	1450	1400	5,75	5,75	C	A	B	72	x	x
9,7	1120	1060	4,75	4,75	C	A	B	72	x	x
9,7	1450	1360	5,75	5,75	C	A	B	72	x	x

Profiltiefe in mm	Tragfähigkeit (kg)		Luftdruck (bar)		Rollwider- stand	Nass- haftung	Rollgeräusch		M+S	3 PMSF
	Einzel	Zwilling	Einzel	Zwilling			Level	dB	M+S	
10	900	850	4,50	4,50	C	B	B	72	x	x
10	1030	975	4,50	4,50	C	B	B	72	x	x
10	1120	1060	4,50	4,50	C	B	B	72	x	x
10	975	925	4,75	4,75	C	B	B	72	x	x
10	975	925	4,75	4,75	C	B	B	72	x	x
10	1250	1180	5,25	5,25	C	B	B	72	x	x
10	1030	975	4,75	4,75	C	B	B	72	x	x
10	1120	1060	4,75	4,75	C	B	B	72	x	x
10	1450	1360	5,75	5,75	C	B	B	72	x	x



PKW - TRAILER REIFEN



PKW - Trailer
Reifen

SERVICE-PLUS BY BOHNENKAMP

Erhalten Sie direkten Zugriff
auf unseren Online-Shop





PKW - Trailer



PR



TL/
TT



Artikel-Nr.	Größe	PR	Last-/ Speed-Index	TT/TL	Fabrikat	Profil	empfohlene Felge	Außen Ø in mm
191.66.100	4.80/4.00 - 8	4	62 M	TL	Deli	S-380	3.75	418
191.66.101	4.80/4.00 - 8	6	70 M	TT	Deli	S-380	3.75	418
192.66.050	4.80/4.00 - 8	6	70 M	TT	Kenda	K371	3.75	403
192.66.051	4.80/4.00 - 8	6	71 M	TL	Kenda	K371	3.75	403
107.44.021	4.80/4.00 - 8	6	70 M	TT	Trailermaxx	C178	3.75	418
198.00.365	4.80/4.00 - 8	8	71 M	TL	Kenda	K385	3.75	405
192.66.055	5.00 - 8	6	77 M	TT	Kenda	K385	3.00	470
107.44.040	5.00 - 8	6	77 M	TT	Trailermaxx	C824	4.50	470
192.66.054	5.00 - 8	10	89 M	TT	Kenda	K385	3.00	473
191.66.110	5.70/5.00 - 8	6	77 M	TL	Deli	S-378	3.75	465
191.66.120	16.5x6.50 - 8	6	73 M	TL	Deli	S-368	5.375	418
191.10.134	16.5x6.50 - 8	8	78 N	TL	Deli	S-368	5.375	420
107.14.870	16.5x6.50 - 8	8	77 M	TL	Cheng Shin	C834	5.375	424
192.66.056	18.5x8.50 - 8	6	78 M	TL	Kenda	K368	7.00	462
107.14.890	18.5x8.5 - 8	6	78 M	TL	Trailermaxx	C834	7.00	473
191.66.130	18.5x8.5 - 8	6	78 M	TL	Deli	S-368	7.00	480
191.10.144	18.5x8.5 - 8	8	85 M	TL	Deli	S-368	7.00	483
107.14.892	18.5x8.5 - 8	8	85 M	TL	Trailermaxx	C834	7.00	478
191.10.163	6.00 - 9	6	85 M	TT	Deli	S-252	4.50	526
191.10.161	6.00 - 9	10	95 M	TT	Deli	S-252	4.50	526
192.66.058	6.90/6.00 - 9	6	85 M	TT	Kenda	K385	4.00	540
192.66.057	6.90/6.00 - 9	10	95 M	TT	Kenda	K385	4.00	550



Cheng Shin C834



Deli S-252



Deli S-368



Deli S-378



Trailermaxx C178









Trailermaxx C824



Trailermaxx C834

Informationen zum EU-Reifenlabel
erhalten Sie auf den Seiten 14 und 15.

					
Breite in mm	Tragfähigkeit in kg	Geschwindigkeit km/h	Luftdruck in bar	Bemerkung	passender Schlauch Artikel-Nr.
119	265	130	4,00		
119	335	130	5,00	inkl. Schlauch	298.00.072
119	335	130	5,90	inkl. Schlauch	298.00.072
119	345	130	6,20		
128	335	130	6,30	inkl. Schlauch	298.00.072
122	345	130	6,30		
140	412	130	5,20		298.00.076
145	412	130	5,20	inkl. Schlauch	298.00.076
142	580	130	8,30		298.00.076
140	412	130	5,30		
166	360	130	4,80		
170	425	140	6,20		
168	412	130	6,20		
220	425	130	3,50		
207	425	130	3,40		
212	425	130	3,40		
212	520	130	4,80		
210	515	130	4,80		
163	510	130	4,10		298.00.091
163	690	130	7,00		298.00.091
175	515	130	4,10		298.00.091
178	690	130	7,00		298.00.091



Deli S-380



Kenda K368



Kenda K371



Kenda K385



PKW - Trailer



PR



TL/
TT



Artikel-Nr.	Größe	PR	Last-/ Speed-Index	TT/TL	Fabrikat	Profil	empfohlene Felge	Außen Ø in mm
191.66.411	4.00 - 10	4	63 M	TL	Deli	S-252	3.00	458
191.66.140	4.00 - 10	6	71 M	TL	Deli	S-252	3.00	458
185.11.045	4.50 - 10	6	76 M	TL	Kenda	K364	3.50	496
107.44.080	4.50 - 10	6	76 M	TT	Cheng Shin	C816	3.50	488
198.00.096	4.50 - 10	6	76 N	TL	Starco	ST-5000	3.50	490
192.66.059	5.00 - 10	4	72 M	TL	Kenda	K364	3.50	509
192.66.061	5.00 - 10	6	79 M	TL	Kenda	K364	3.50	513
192.66.060	5.00 - 10	8	84 M	TL	Kenda	K364	3.50	513
191.66.145	5.20 - 10	4	72 M	TL	Deli	S-252	3.50	525
107.41.105	5.20/5.00 - 10	6	74/72 M	TL	Trailermaxx	C824	3.50	517
107.41.200	18 x 8.0 - 10	6	98 N	TL	Trailermaxx	M-8001	6.00	450
191.10.177	20.5x8.0 - 10	6	84 M	TL	Deli	S-368	6.00	528
192.66.063	20.5x8.0 - 10	8	90 M	TL	Kenda	K368	6.00	516
191.66.150	20.5x8.0 - 10	10	95 M	TL	Deli	S-368	6.00	528
107.14.940	20.5x8.0 - 10	10	98 M	TL	Trailermaxx	C834	6.00	520
192.66.062	20.5x8.0 - 10	10	98 N	TL	Kenda	K368	6.00	526
192.66.070	20.5x10.0 - 10	8	98 M	TL	Kenda	K399 Loadstar	8.00	524
107.14.960	20.5x10.0 - 10	10	98 M	TL	Cheng Shin	C834	8.50	520
191.66.141	145/80 B 10		74 N	TL	Deli	S-255	3.50	495
191.66.142	145/80 B 10		84 N	TL	Deli	S-255	3.50	495
192.66.064	145/80 R 10		74 N	TL	Kenda	KR209 KargoTrail 3G	3.50	486
107.45.010	145 R 10		74 N	TL	Trailermaxx	CR-966	3.50	492
198.66.000	145 R 10		84/82 N	TL	Trailermaxx	CR-966	4.00	490



Cheng Shin C816



Deli S-252

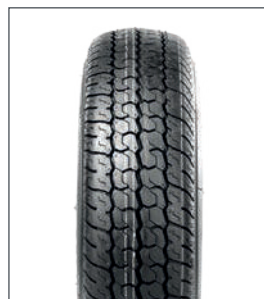

Deli S-255



Deli S-368



Starco ST-5000



Trailermaxx C824



Trailermaxx C834

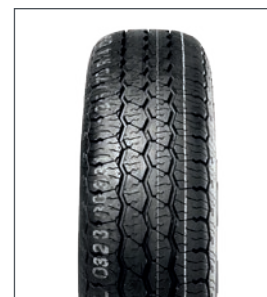

Trailermaxx CR-966

Informationen zum EU-Reifenlabel erhalten Sie auf den Seiten 14 und 15.

				M+S			
Breite in mm	Tragfähigkeit in kg	Geschwindigkeit km/h	Luftdruck in bar	M+S	3PMSF	Bemerkung	passender Schlauch Artikel-Nr.
106	275	130	3,00				
106	350	130	3,50				
132	400	130	4,12				
130	400	130	3,60			inkl. Schlauch	298.00.112
128	400	140	4,25	x			
124	355	130	2,80				
138	437	130	3,40				
138	500	130	4,50				
141	355	130	3,50				
136	375	130	3,00				
187	750	140	6,00				
208	500	130	3,40				
198	600	130	4,90				
208	695	130	6,20				
200	750	130	6,25				
201	750	140	6,20				
253	750	130	6,00				
248	750	130	6,25				
135	375	140	2,50				
135	500	140	3,00				
144	375	140	3,40	x			
147	375	140	2,50	x			
143	500	140	4,50	x			



Kenda K364



Kenda K368



Kenda K399 Loadstar



**Kenda KR209
KargoTrail 3G**



Trailermaxx M-8001

PKW - Trailer
Reifen



PKW - Trailer



PR



TL/
TT



Artikel-Nr.	Größe	PR	Last-/ Speed-Index	TT/TL	Fabrikat	Profil	empfohlene Felge	Außen Ø in mm
192.66.065	145 R 10 C		84/82 N	TL	Kenda	KR101 MasterTrail 3G	3.50	492
185.45.000	145 R 10 C		84/82 N	TL	BK Trailer	204	4.00	492
191.66.147	195/50 B 10		98 N	TL	Deli	S-372	6.00	460
192.66.067	195/50 B 10		98 N	TL	Kenda	K399 Loadstar	6.00	460
192.66.081	195/55 R 10 C		98/96 N	TL	Kenda	KR500 Winter Trailer	6.00	468
192.66.066	195/55 R 10 C		98/96 N	TL	Kenda	KR101 MasterTrail 3G	6.00	468
198.66.002	195/55 R 10 C		98/96 N	TL	Compass	ST-5000	6.00	468
185.45.015	195/55 R 10 C		98/96 N	TL	BK Trailer	204	6.00	468
183.66.100	195/55 R 10 C		98/96 N	TL	Security	TR603	6.00	468
185.45.010	195/55 R 10 C		98/96 N	TL	Eternity	ST 6000	6.00	468
107.65.011	195/55 R 10 C		98/96 P	TL	Trailermaxx	CR-966	6.00	469
192.66.072	205/50 - 10	12	104 N	TL	Kenda	K399 Pro Tour	6.00	466
192.66.069	205/65 - 10	10	98 N	TL	Kenda	K399 Loadstar	6.00	517
198.66.007	125 R 12 C		81 J	TL	Trailermaxx	CR-966	3.00	512
198.00.482	140/70 R 12 C		86 N	TL	Starco	JA-6000 MasterTrail	4.00	506
192.66.102	155/70 R 12 C		104/102 N	TL	Kenda	KR101 MasterTrail 3G	4.50	527
185.45.017	155/70 R 12 C		104/102 N	TL	BK Trailer	204	4.50	523
198.66.005	155/70 R 12 C		104 N	TL	GT Radial	KargoMax ST 6000	4.50	523
192.66.074	155/70 R 12 C		104/101 N	TL	Kenda	KR16 Kargo Pro	4.00	523
192.66.100	155/70 R 12 C		104/101 N	TL	Kenda	KR500 Winter Trailer	4.50	523
107.45.027	155/70 R 12 C		104/102 N	TL	Maxxis	UE-168N	4.50	525
183.66.121	155/70 R 12 C		104/102 N	TL	Security	TR603	4.50	523



BK Trailer 204



Compass ST-5000

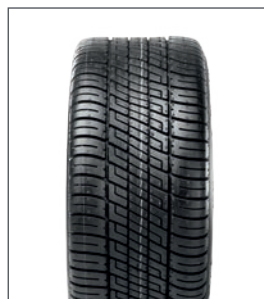

Deli S-372

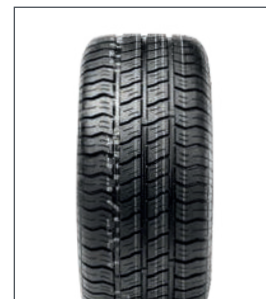

Eternity ST 6000



Kenda KR16 Kargo Pro



**Maxxis UE-168 /
UE-168N**



Security TR603

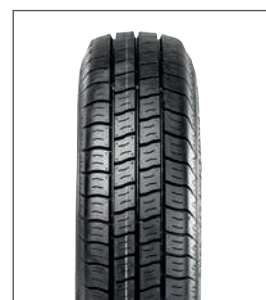

**Starco JA-6000
MasterTrail**

Informationen zum EU-Reifenlabel erhalten Sie auf den Seiten 14 und 15.

Breite in mm	Tragfähigkeit in kg	Geschwindigkeit km/h	Luftdruck in bar	M+S	3PMSF	Rollwiderstand	Nasshaftung	Rollgeräusch Level dB
143	500	140	4,50	x				
147	500	140	4,50	x				
198	750	140	6,20					
185	750	140	6,00					
201	750	140	6,21	x				
201	750	140	6,20	x				
189	750	140	6,25	x				
201	750	140	6,20	x				
201	750	140	6,25	x				
201	750	140	6,40	x				
196	750	150	6,25	x				
204	900	140	7,90					
213	750	140	6,20					
122	462	100	5,00	x		D	B	B 72
138	530	140	4,25	x		E	C	B 70
157	900	140	6,50	x		B	C	B 72
157	900	140	6,50	x		D	D	B 71
157	900	140	6,50	x		C	C	B 70
152	900	140	6,50	x		D	C	B 70
157	900	140	6,55	x	x	E	B	B 72
158	900	140	6,50			C	B	B 71
157	900	140	6,30	x		D	C	B 72

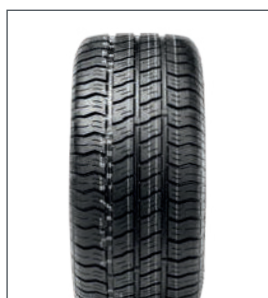

GT Radial KargoMax ST 6000

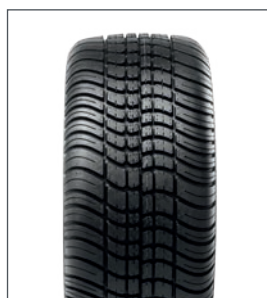

Kenda K399 Loadstar / K399 Pro Tour



Kenda KR500 Winter Trailer



Kenda KR101 MasterTrail 3G



Trailermaxx CR-966

PKW - Trailer Reifen



PKW - Trailer



TL/
TT



Artikel-Nr.	Größe	Last-/ Speed-Index	TL/ TT	Fabrikat	Profil	empfohlene Felge	Außen Ø in mm
107.65.028	155 R 12 C	88/86 N	TL	Maxxis	UE-168	4.50	556
199.65.185	155 R 12 C	88/86 Q	TL	Nankang	CW-25	4.50	550
192.66.107	185/60 R 12 C	104/102 N	TL	Kenda	KR101 MasterTrail 3G	5.50	529
185.45.018	185/60 R 12 C	104/102 N	TL	BK Trailer	204	5.50	527
198.66.006	185/60 R 12 C	104 N	TL	GT Radial	KargoMax ST 6000	6.00	527
192.66.105	185/60 R 12 C	104/101 N	TL	Kenda	KR500 Winter Trailer	5.50	526
192.66.075	185/60 R 12 C	104/101 N	TL	Kenda	KR16 Kargo Pro	5.50	528
107.45.030	185/60 R 12 C	104/101 N	TL	Trailermaxx	CR-966	5.50	527
183.45.051	185/60 R 12 C	104/101 N	TL	Security	TR603	5.50	527
199.65.187	195/60 R 12 C	104/102 N	TL	GT Radial	KargoMax ST 6000	6.00	530
107.65.035	195/60 R 12 C	104/102 N	TL	Trailermaxx	CR-966	5.50	536
183.45.060	195/60 R 12 C	108/106 N	TL	Security	TR603	5.50	537
107.65.030	225/55 R 12 C	104 N	TL	Trailermaxx	CR-966	7.00	554
192.66.077	225/55 R 12 C	112 N	TL	Kenda	KR33A	7.00	554
192.66.113	135/80 R 13	70 N	TL	Kenda	KR209 KargoTrail 3G	3.50	546
183.45.103	135/80 R 13	74 N	TL	Security	AW414	4.00	546
198.66.037	145/70 R 13	84 N	TL	GT Radial	KargoMax ST 4000	4.00	534
192.66.114	145/80 R 13	75 N	TL	Kenda	KR209 KargoTrail 3G	4.00	562
192.66.115	145/80 R 13	78 N	TL	Kenda	KR209 KargoTrail 3G	4.00	562
185.45.320	145/80 R 13	78 N	TL	Boka Trailer Line	FT 01	4.50	562
185.45.020	145/80 R 13	78 N	TL	BK Trailer	201	4.00	562
198.66.014	145/80 R 13	79 N	TL	GT Radial	KargoMax ST 4000 XL	4.00	562



BK Trailer 201



BK Trailer 204



Boka Trailer Line FT 01

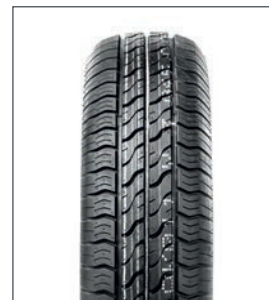

**GT Radial KargoMax ST 4000
ST 4000 XL**



Kenda KR33A

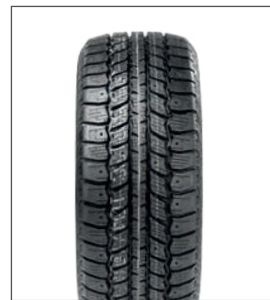

**Kenda KR500 Winter
Trailer**



Nankang CW-25

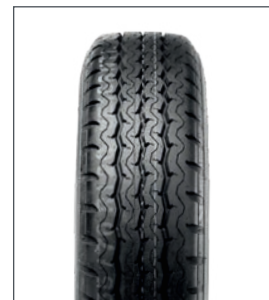

Maxxis UE-168

Informationen zum EU-Reifenlabel erhalten Sie auf den Seiten 14 und 15.

Breite in mm	Tragfähigkeit in kg	Geschwindigkeit km/h	Luftdruck in bar	M+S	3PMSF	Rollwiderstand	Nasshaftung	Rollgeräusch Level dB
156	560	140	4,33			D	B	B 70
157	530	160	4,50			C	C	B 72
187	900	140	6,50	x		B	C	B 72
189	900	140	6,50	x		D	D	B 72
187	900	140	6,50	x		C	C	B 70
189	900	140	6,55	x	x	E	B	B 72
189	900	140	6,50	x		D	C	B 70
185	900	140	6,50	x		D	B	B 72
189	900	140	6,50	x		D	C	B 72
194	900	140	6,55	x		C	C	B 70
193	900	140	6,50	x		D	B	B 72
201	1000	140	6,50	x		C	C	B 72
232	900	140	5,30	x		C	B	A 69
225	1120	140	6,90			D	C	B 71
133	335	140	3,00	x		C	D	B 69
133	375	140	2,70	x		D	C	B 70
150	500	140	3,40	x		D	C	B 69
145	387	140	3,00	x		C	D	B 69
145	425	140	3,40	x		C	D	B 69
150	425	140	3,00	x		D	C	B 70
145	425	140	2,80	x		D	D	B 71
145	437	140	3,00	x		D	C	B 70

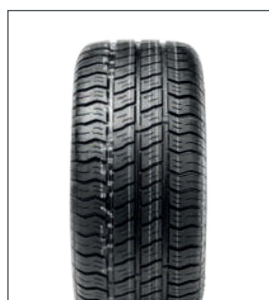

GT Radial KargoMax ST 6000

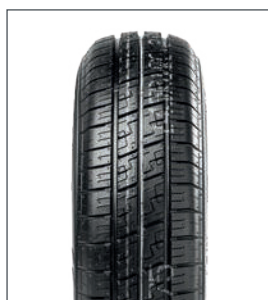

Kenda KR101 MasterTrail 3G

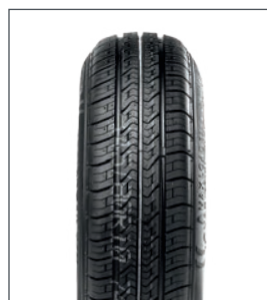

Kenda KR209 KargoTrail 3G

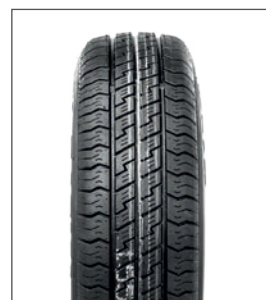

Kenda KR16 Kargo Pro



Security AW414



Security TR-603



Trailermaxx CR-966

PKW - Trailer Reifen



PKW - Trailer



TL/
TT



Artikel-Nr.	Größe	Last-/ Speed-Index	TT/TL	Fabrikat	Profil	empfohlene Felge	Außen Ø in mm
183.45.266	145/80 R 13	79 N	TL	Security	AW414	4.00	562
192.66.116	155/70 R 13	74 N	TL	Kenda	KR209 KargoTrail 3G	4.50	548
198.66.017	155/70 R 13	78 N	TL	GT Radial	KargoMax ST 4000	4.50	548
185.45.330	155/70 R 13	79 N	TL	Boka Trailer Line	FT 01	4.50	546
183.45.264	155/70 R 13	79 N	TL	Security	AW414	4.00	548
185.45.335	155/80 R 13	84 N	TL	Boka Trailer Line	FT 01	4.50	578
185.45.030	155/80 R 13	84 N	TL	BK Trailer	202	4.50	578
183.45.289	155/80 R 13	84 N	TL	Security	AW418	4.50	578
198.66.009	155 R 13	84 N	TL	GT Radial	KargoMax ST 4000	4.50	578
107.45.050	155 R 13	84 N	TL	Trailermaxx	CR-966	4.50	581
107.45.052	155 R 13	91/89 N	TL	Trailermaxx	CR-966	4.50	581
192.66.109	155 R 13 C	91/89 N	TL	Kenda	KR500 Winter Trailer	4.00	576
198.66.010	155 R 13 C	91/89 N	TL	GT Radial	KargoMax ST 6000	4.50	578
183.45.277	155 R 13 C	91/89 N (90/88 R)	TL	Security	TR603	4.50	578
192.66.118	165/70 R 13	79 N	TL	Kenda	KR209 KargoTrail 3G	5.00	564
198.66.018	165/70 R 13	80 N	TL	GT Radial	KargoMax ST 4000	5.00	562
183.45.285	165/70 R 13	84 N	TL	Security	AW414	4.00	562
192.66.121	165 R 13 C	96/94 N	TL	Kenda	KR101 MasterTrail 3G	4.50	596
185.45.040	165 R 13 C	96/94 N	TL	BK Trailer	203	4.50	596
198.66.012	165 R 13 C	96/94 N	TL	GT Radial	KargoMax ST 6000	4.50	598
183.66.151	165 R 13 C	96 N (94/92 R)	TL	Security	TR603	4.50	594
192.66.119	175/70 R 13	86 N	TL	Kenda	KR209 KargoTrail 3G	5.00	578



BK Trailer 202



BK Trailer 203



Boka Trailer Line FT 01

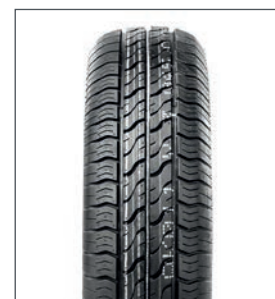

**GT Radial KargoMax
ST 4000 / XL**



**Kenda KR500
Winter Trailer**



Security AW414



Security AW418



Security TR-603

Informationen zum EU-Reifenlabel erhalten Sie auf den Seiten 14 und 15.

Breite in mm	Tragfähigkeit in kg	Geschwindigkeit km/h	Luftdruck in bar	M+S	3PMSF	Rollwiderstand	Nasshaftung	Rollgeräusch Level	Rollgeräusch dB
145	437	140	2,70	x		D	C	B	70
157	375	140	3,00	x		C	D	B	69
157	425	140	3,10	x		D	C	B	69
153	437	140	3,00	x		D	C	B	71
157	437	140	2,70	x		D	C	B	70
162	500	140	3,00	x		D	C	B	71
157	500	140	2,90	x		D	D	B	72
157	500	140	2,70	x		D	C	B	70
157	500	140	3,10	x		C	C	B	70
157	500	140	2,70	x		D	B	B	72
158	615	140	2,70	x		C	B	B	72
149	615	140	4,50	x	x	D	B	B	72
157	615	140	4,50	x		C	C	B	70
157	615	140	4,50	x		D	C	B	72
172	437	140	3,00	x		C	D	B	69
170	450	140	2,60	x		D	C	B	69
170	500	140	2,70	x		C	C	B	70
167	710	140	4,50	x		B	C	B	72
167	710	140	4,48	x		D	D	B	72
167	710	140	4,50	x		C	C	B	70
165	710	140	4,50	x		D	C	B	72
177	530	140	3,40	x		C	D	B	69

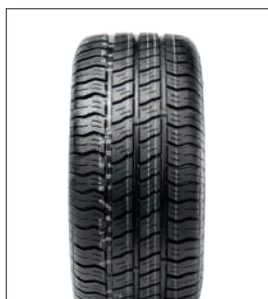

GT Radial KargoMax ST 6000



Kenda KR101 MasterTrail 3G

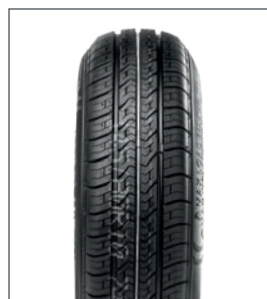

Kenda KR209 KargoTrail 3G



Trailermaxx CR-966



PKW - Trailer



TL/
TT



Artikel-Nr.	Größe	Last-/ Speed-Index	TT/TL	Fabrikat	Profil	empfohlene Felge	Außen Ø in mm
185.45.050	175/70 R 13	86 N	TL	BK Trailer	202	5.00	576
183.45.287	175/75 R 13	86 N	TL	Security	AW414	4.50	576
198.66.011	175 R 13 C	97/95 N	TL	GT Radial	Maxmiler-X	5.00	610
192.66.120	185/70 R 13	93 N	TL	Kenda	KR209 KargoTrail 3G	5.50	590
185.45.060	185/70 R 13	93 N	TL	BK Trailer	202	5.50	590
198.66.015	185/70 R 13	93 N	TL	GT Radial	KargoMax ST 4000	5.50	590
183.45.304	185/70 R 13	93 N	TL	Security	AW414	4.50	590
198.66.008	185/70 R 13 C	106/104 N	TL	GT Radial	Savero	5.50	594
192.66.122	195/50 R 13 C	104/102 N	TL	Kenda	KR101 MasterTrail 3G	6.00	526
192.66.110	195/50 R 13 C	104/101 N	TL	Kenda	KR500 Winter Trailer	6.00	529
107.45.200	195/50 R 13 C	104/101 N	TL	Trailermaxx	CR-966	5.50	525
185.45.360	195/50 R 13 C	104/102 N	TL	Boka Trailer Line	FT 02	6.00	526
192.66.076	195/50 R 13 C	104/101 N	TL	Kenda	KR16 Kargo Pro	6.00	527
198.66.013	195/50 R 13 C	104/101 N	TL	GT Radial	KargoMax ST 6000	6.00	526
107.45.198	195/50 R 13 C	104/101 N	TL	Maxxis	MA-LAS	6.00	531
183.45.331	195/50 R 13 C	104/101 N	TL	Security	TR603	6.00	526
199.65.200	165 R 14 C	97/95 R	TL	Nankang	CW-25	4.50	623
192.66.132	175 R 14 C	99/98 N	TL	Kenda	KR101 MasterTrail 3G	5.00	634
198.66.025	175 R 14 C	99/98 N	TL	GT Radial	Maxmiler-X	5.00	634
199.65.225	175 R 14 C	99/98 R	TL	Nankang	CW-25	5.00	635
192.66.130	185/65 R 14	93 N	TL	Kenda	KR209 KargoTrail 3G	5.00	596
185.45.080	185/65 R 14	93 N	TL	BK Trailer	202	5.00	596



BK Trailer 202



Boka Trailer Line FT 02



**GT Radial KargoMax
ST 4000**

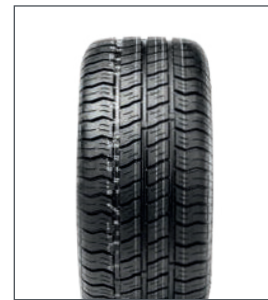

**GT Radial KargoMax
ST 6000**



**Kenda KR500
Winter Trailer**

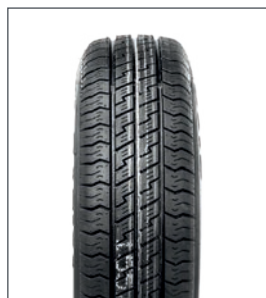

Kenda KR16 Kargo Pro



Maxxis MA-LAS



Nankang CW-25

Informationen zum EU-Reifenlabel erhalten Sie auf den Seiten 14 und 15.

Breite in mm	Tragfähigkeit in kg	Geschwindigkeit km/h	Luftdruck in bar	M+S	3PMSF	Rollwiderstand	Nasshaftung	Rollgeräusch Level	Rollgeräusch dB
177	530	140	2,90	x		D	D	B	72
177	530	140	2,70	x		D	C	B	70
177	730	140	4,50			D	C	B	71
191	650	140	3,40	x		A	D	B	69
197	650	140	3,00	x		D	D	B	72
189	650	140	3,00	x		D	C	B	70
189	650	140	2,70	x		C	C	B	70
192	950	140	6,00	x		C	B	B	73
195	900	140	6,50	x		B	C	B	72
192	900	140	6,55	x	x	E	B	B	72
188	900	140	6,25	x		D	C	B	72
196	900	140	6,50	x		C	B	B	72
198	900	140	6,50	x		D	C	B	70
195	900	140	6,50	x		C	C	B	72
190	900	140	6,50	x	x	E	C	B	71
201	900	140	6,50	x		D	C	B	72
166	730	170	4,50			C	C	B	72
178	775	140	4,50	x		B	C	B	72
178	775	140	4,50			E	C	B	71
178	775	170	4,50			C	C	B	72
185	650	140	3,40	x		B	D	B	69
189	650	140	2,90	x		D	D	B	72



GT Radial Maxmiler-X



GT Radial Savero



Kenda KR101 MasterTrail 3G

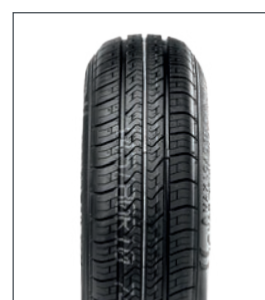

Kenda KR209 KargoTrail 3G



Security AW414



Security TR-603



Trailermaxx CR-966

PKW - Trailer Reifen



PKW - Trailer



TL/
TT



Artikel-Nr.	Größe	Last-/ Speed-Index	TT/TL	Fabrikat	Profil	empfohlene Felge	Außen Ø in mm
185.45.370	185/65 R 14	93 N	TL	Boka Trailer Line	FT 01	5.50	596
198.66.035	185/65 R 14	93 N	TL	GT Radial	KargoMax ST 4000	5.50	596
107.45.238	185/65 R 14	93/91 N	TL	Trailermaxx	CR-965	5.50	600
183.45.403	185/65 R 14	93 N	TL	Security	AW414	5.50	596
192.66.128	185 R 14 C	104/102 N	TL	Kenda	KR500 Winter Trailer	5.50	650
192.66.134	185 R 14 C	104/102 N	TL	Kenda	KR101 MasterTrail 3G	5.00	650
185.45.090	185 R 14 C	104/102 N	TL	BK Trailer	203	5.00	650
185.45.380	185 R 14 C	104/102 N	TL	Boka Trailer Line	FT 02	5.50	650
198.66.023	185 R 14 C	104/102 N	TL	GT Radial	KargoMax ST 6000	5.00	650
183.66.207	185 R 14 C	102/100 S (104 N)	TL	Security	TR603	5.50	652
183.45.411	195/65 R 14	96 N	TL	Security	AW414	6.00	610
192.66.131	195/70 R 14	98 N	TL	Kenda	KR209 KargoTrail 3G	6.00	632
185.45.100	195/70 R 14	96 N	TL	BK Trailer	202	6.00	630
185.45.390	195/70 R 14	96 N	TL	Boka Trailer Line	FT 01	6.00	630
198.66.021	195/70 R 14	96 N	TL	GT Radial	KargoMax ST 4000	6.00	630
107.45.255	195/70 R 14	96 N	TL	Trailermaxx	CR-966	6.00	630
183.45.424	195/70 R 14	96 N	TL	Security	AW414	5.50	630
198.66.022	195/70 R 14 C	104/102 N	TL	GT Radial	KargoMax ST 6000	6.00	630
192.66.135	195 R 14 C	108/106 N	TL	Kenda	KR101 MasterTrail 3G	5.50	666
185.45.110	195 R 14 C	108/106 N	TL	BK Trailer	203	5.50	666
198.66.027	195 R 14 C	106/104 N	TL	GT Radial	Maxmiler-X	5.50	666
183.66.351	195 R 14 C	106/104 R (108 N)	TL	Security	TR603	5.50	666



BK Trailer 202

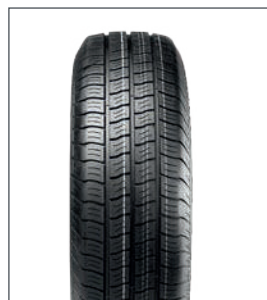

BK Trailer 203



Boka Trailer Line FT 01



Boka Trailer Line FT 02



Kenda KR209
KargoTrail 3G

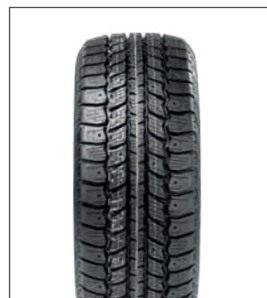

Kenda KR500
Winter Trailer



Security AW414



Security TR603

Informationen zum EU-Reifenlabel erhalten Sie auf den Seiten 14 und 15.

Breite in mm	Tragfähigkeit in kg	Geschwindigkeit km/h	Luftdruck in bar	M+S	3PMSF	Rollwiderstand	Nasshaftung	Rollgeräusch Level dB
189	650	140	3,40	x		D	C	B 71
189	650	140	3,40	x		D	C	B 69
192	650	140	2,80	x		C	C	B 72
189	650	140	2,70	x		D	C	B 70
186	900	140	4,50	x	x	E	B	B 72
188	900	140	4,50	x		B	C	B 72
188	900	140	4,48	x		D	D	B 72
188	900	140	4,50	x		C	B	B 71
188	900	140	4,50	x		C	C	B 70
188	900	140	4,50	x		D	C	B 72
201	710	140	3,40	x		C	C	B 71
201	750	140	3,40	x		A	D	B 69
201	710	140	2,90	x		D	D	B 72
201	710	140	3,40	x		D	C	B 72
201	710	140	3,10	x		C	C	B 72
198	710	140	2,70	x		C	B	B 72
201	710	140	2,70	x		C	C	B 71
201	900	140	4,50	x		C	C	B 70
198	1000	140	5,00	x		A	C	B 72
198	1000	140	5,00	x		D	D	B 72
198	950	140	4,50			C	C	C 73
198	1000	140	4,50	x		D	C	B 72

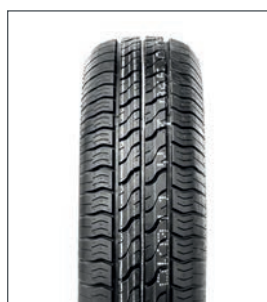

GT Radial KargoMax ST 4000

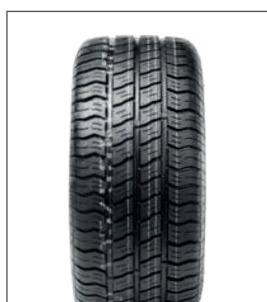

GT Radial KargoMax ST 6000



GT Radial Maxmiler-X



Kenda KR101 MasterTrail 3G



Trailermaxx CR-965

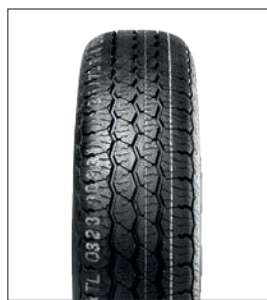

Trailermaxx CR-966

PKW - Trailer Reifen



PKW - Trailer



TL/
TT



Artikel-Nr.	Größe	Last-/ Speed-Index	TT/TL	Fabrikat	Profil	empfohlene Felge	Außen Ø in mm
192.66.136	205 R 14 C	109/107 N	TL	Kenda	KR101 MasterTrail 3G	6.00	688
185.45.120	205 R 14 C	109/107 N	TL	BK Trailer	203	6.00	686
198.66.036	205 R 14 C	109/107 P	TL	GT Radial	Maxmiler Pro	5.50	686
192.66.137	215 R 14 C	116/114 N	TL	Kenda	KR101 MasterTrail 3G	6.00	700
185.45.130	215 R 14 C	116/114 N	TL	BK Trailer	203	6.00	700
107.45.510	175/65 R 15	93 N (95 J)	TL	Trailermaxx	CR-966	5.00	609
192.66.145	195/65 R 15	98 N	TL	Kenda	KR209 KargoTrail 3G	6.00	636
185.45.140	195/65 R 15	93 N	TL	BK Trailer	202	6.00	635
198.66.032	195/65 R 15	95 N	TL	GT Radial	KargoMax ST 4000	6.00	635
183.45.506	195/65 R 15	95 N	TL	Security	AW414	5.50	635
198.66.031	195/70 R 15 C	104/102 N	TL	GT Radial	KargoMax ST 6000	6.00	655
183.66.370	195/70 R 15 C	104/102 R (108 N)	TL	Security	TR603	6.00	655
199.65.365	205/65 R 15 C	102/100 T	TL	Ovation	V-02	6.00	647
198.66.030	205/70 R 15 C	106/104 R	TL	GT Radial	Maxmiler Pro	6.00	669
192.66.146	225/70 R 15 C	116/114 N	TL	Kenda	KR101 MasterTrail 3G	6.50	697
198.66.033	175/75 R 16 C	101/99 R (104 N)	TL	GT Radial	Maxmiler EX	5.00	668



BK Trailer 202

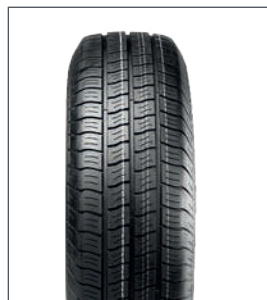

BK Trailer 203

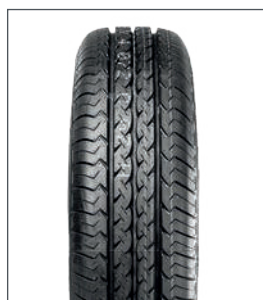

GT Radial Maxmiler EX

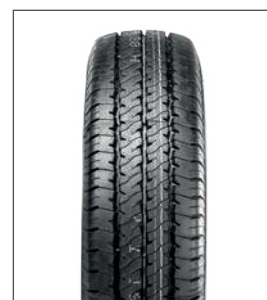

GT Radial Maxmiler Pro



Ovation V-02



Security AW414



Security TR-603

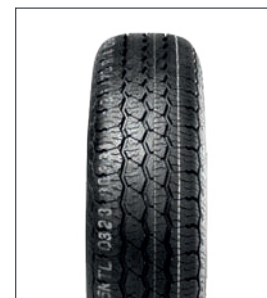

Trailermaxx CR-966

Informationen zum EU-Reifenlabel
erhalten Sie auf den Seiten 14 und 15.

Breite in mm	Tragfähigkeit in kg	Geschwindigkeit km/h	Luftdruck in bar	M+S	3PMSF	Rollwiderstand	Nasshaftung	Level	dB
208	1030	140	4,50	x		B	C	B	72
208	1030	140	4,48	x		D	D	B	72
208	1030	150	4,50			D	C	B	69
218	1250	140	4,75	x		A	C	B	72
218	1250	140	4,75	x		D	D	B	72
177	650	140	6,25			D	C	B	72
200	750	140	3,40	x		B	D	B	69
201	650	140	2,90	x		D	D	B	72
201	690	140	3,00	x		C	C	B	72
201	690	140	2,90	x		C	C	B	71
201	900	140	4,50	x		C	C	B	70
201	900	170	4,50	x		D	C	B	72
209	850	190	3,75			D	C	B	72
209	950	170	4,50	x		C	C	B	71
228	1250	140	4,75	x		A	C	B	72
177	825	170	4,80	x		D	C	B	70



GT Radial KargoMax ST 4000

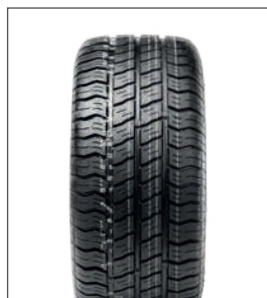

GT Radial KargoMax ST 6000



Kenda KR101 MasterTrail 3G

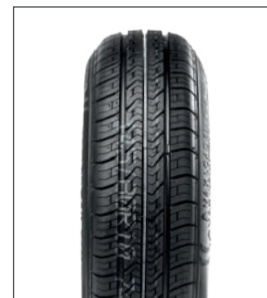

Kenda KR209 KargoTrail 3G



LKW FELGEN



SERVICE-PLUS BY BOHNENKAMP

Erhalten Sie direkten Zugriff
auf unseren Online-Shop





Artikel-Nr.	Felgenreöße	Anschluss	Bolzenloch- ausführung	Zentrierung	ET	HMA	Ventilposition
309.64.010	7.50 x 19.5	8/221/275	Ø 24, M20/M22	MZ	+137	159	ILV
309.64.015	7.50 x 19.5	8/221/275	Ø 24, M20/M22	MZ	+137	159	ILV
309.64.020	7.50 x 19.5	8/221/275	Ø 32, M20/M22	MZ	+137	159	ILV
309.64.025	7.50 x 19.5	8/221/275	Ø 32, M20/M22	MZ	+137	159	ILV
309.64.030	8.25 x 22.5	10/281/335	Ø 26, M20/M22	MZ	+148	170	ILV
309.64.035	8.25 x 22.5	10/281/335	Ø 26, M20/M22	MZ	+148	170	ILV
309.64.040	8.25 x 22.5	10/281/335	Ø 32, M20/M22	MZ	+148	170	ILV
309.64.045	8.25 x 22.5	10/281/335	Ø 32, M20/M22	MZ	+148	170	ILV
309.64.050	9.00 x 22.5	10/281/335	Ø 26, M20/M22	MZ	+153	175	ILV
309.64.055	9.00 x 22.5	10/281/335	Ø 26, M20/M22	MZ	+153	175	ILV
309.64.060	9.00 x 22.5	10/281/335	Ø 32, M20/M22	MZ	+153	175	ILV
309.64.065	9.00 x 22.5	10/281/335	Ø 32, M20/M22	MZ	+153	175	ILV
309.64.070	11.75 x 22.5	10/281/335	Ø 26, M20/M22	MZ	0		ALV
309.64.075	11.75 x 22.5	10/281/335	Ø 26, M20/M22	MZ	0		ALV
309.64.080	11.75 x 22.5	10/281/335	Ø 32, M20/M22	MZ	0		ALV
309.64.085	11.75 x 22.5	10/281/335	Ø 32, M20/M22	MZ	0		ALV
309.64.090	11.75 x 22.5	10/281/335	Ø 26, M20/M22	MZ	+120		ALV
309.64.095	11.75 x 22.5	10/281/335	Ø 26, M20/M22	MZ	+120		ALV
309.64.100	11.75 x 22.5	10/281/335	Ø 32, M20/M22	MZ	+120		ALV
309.64.105	11.75 x 22.5	10/281/335	Ø 32, M20/M22	MZ	+120		ALV
309.64.110	11.75 x 22.5	10/281/335	Ø 26, M20/M22	MZ	+135		ALV
309.64.115	11.75 x 22.5	10/281/335	Ø 26, M20/M22	MZ	+135		ALV
309.64.120	11.75 x 22.5	10/281/335	Ø 32, M20/M22	MZ	+135		ALV
309.64.125	11.75 x 22.5	10/281/335	Ø 32, M20/M22	MZ	+135		ALV

MZ = mittenzentriert
 ILV = innenliegendes Ventil
 ALV = außenliegendes Ventil





Tragfähigkeit [kg]	Geschwindigkeit [km/h]	Gewicht [kg]	Oberfläche	Zusatzinfo	Abbildung
3039	130	17,50	poliert	mit Ventil	LA2
3039	130	17,50	poliert + Accu-Shield	mit Ventil	LA2
3039	130	17,30	poliert	mit Ventil	LA2
3039	130	17,30	poliert + Accu-Shield	mit Ventil	LA2
3650	130	23,60	poliert	mit Ventil	LA1
3650	130	23,60	poliert + Accu-Shield	mit Ventil	LA1
3650	130	23,40	poliert	mit Ventil	LA1
3650	130	23,40	poliert + Accu-Shield	mit Ventil	LA1
4125	130	24,60	poliert	mit Ventil	LA1
4125	130	24,60	poliert + Accu-Shield	mit Ventil	LA1
4125	130	24,40	poliert	mit Ventil	LA1
4125	130	24,40	poliert + Accu-Shield	mit Ventil	LA1
5000	130	23,10	poliert	mit Ventil	LA3
5000	130	23,10	poliert + Accu-Shield	mit Ventil	LA3
5000	130	22,90	poliert	mit Ventil	LA3
5000	130	22,90	poliert + Accu-Shield	mit Ventil	LA3
5000	130	24,80	poliert	mit Ventil	LA1
5000	130	24,80	poliert + Accu-Shield	mit Ventil	LA1
5000	130	24,60	poliert	mit Ventil	LA1
5000	130	24,60	poliert + Accu-Shield	mit Ventil	LA1
5000	130	25,90	poliert	mit Ventil	LA1
5000	130	25,90	poliert + Accu-Shield	mit Ventil	LA1
5000	130	25,70	poliert	mit Ventil	LA1
5000	130	25,70	poliert + Accu-Shield	mit Ventil	LA1

**Bis zu 5 Jahre
Herstellergarantie**

+ ACCU-SHIELD

XP Alufelge - POLISH

- Premium Politur auf beiden Seiten
- strahlende Oberflächen
- geringes Eigengewicht
- einfach zu reinigen mit Handwäsche

XPC Alufelge - POLISH

- Premium Politur auf beiden Seiten
- strahlende Oberflächen
- geringes Eigengewicht
- + spezielle Oberflächenbehandlung "ACCU-SHIELD"
- + herausragender Selbstreinigungseffekt



Radbefestigungen



Artikel-Nr.	Beschreibung 1	Beschreibung 2	Beschreibung 3	Abbildung
404.81.943	Radmutter - M18 X 1.5, kurze Führung	SW 27 mm, Ø25/42 mm, Höhe 25/35 mm	geometisiert, für Alufelgen	R1
404.81.944	Radmutter - M18 X 1.5, lange Führung	SW 27 mm, Ø25/42 mm, Höhe 25/52 mm	geometisiert, für Alufelgen	R2
404.81.945	Radmutter - M20 X 1.5, kurze Führung	SW 30 mm, Ø28.5/52 mm, Höhe 30/39 mm	geometisiert, für Alufelgen	R1
404.81.946	Radmutter - M20 X 1.5, lange Führung	SW 30 mm, Ø28.5/52 mm, Höhe 27/62 mm	geometisiert, für Alufelgen	R2
404.81.315	Radmutter - M22 x 1.5, ohne Führung	SW 32 mm, Ø46 mm, Höhe 26 mm	geometisiert, für Stahl-/Alufelgen	R4
404.81.330	Radmutter - M22 x 1.5, kurze Führung	SW 32 mm, Ø30.5/53 mm, Höhe 27/34 mm	geometisiert, für Alufelgen	R1
404.81.942	Radmutter - M22 X 1.5, lange Führung	SW 32 mm, Ø30.5/50 mm, Höhe 26/46 mm	geometisiert, für Alufelgen	R2
404.81.335	Radmutter - M22 x 1.5, lange Führung, Zwilling	SW 32 mm, Ø30.5/53 mm, Höhe 27/62 mm	geometisiert, für Alufelgen	R2
404.81.949	Radmutter - Scania, 7/8" 11BSF, kurze Führung	SW 32 mm, Ø30.5/53 mm, Höhe 27/39 mm	geometisiert, für Alufelgen	R1
404.81.950	Radmutter - Scania, 7/8" 11BSF, lange Führung	SW 32 mm, Ø30.5/53 mm, Höhe 27/62 mm	geometisiert, für Alufelgen	R2
404.81.951	Radmutter - Volvo, 7/8" 14UNF, kurze Führung	SW 32 mm, Ø30.5/53 mm, Höhe 27/39 mm	geometisiert, für Alufelgen	R1
404.81.952	Radmutter - Volvo, 7/8" 14UNF, lange Führung	SW 32 mm, Ø30.5/53 mm, Höhe 27/62 mm	geometisiert, für Alufelgen	R2
404.81.340	Radmutterkappe - Kunststoff verchromt	SW 32 mm, Ø55 mm, Höhe 38 mm		R3
404.81.932	Radmutterkappe - Kunststoff verchromt	SW 32 mm, Ø58 mm, Höhe 45 mm		R3
404.81.933	Radmutterkappe - Edelstahl	SW 32 mm, Ø55 mm, Höhe 45 mm		R5
404.81.934	Abzieher für Radmutterkappe LKW			
404.81.935	LKW-Inlay Kunststoff für Radmuttern			

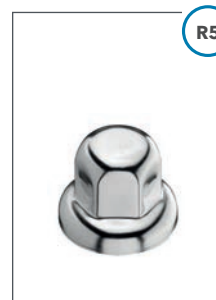

LKW

Artikel-Nr.	Ventilausführung	Ventil- bezeichnung	Ventil- bezeichnung ETRTO	Ventilloch- durchmesser [mm]	Länge [mm]	max. Luftdruck [bar]	Winkel [°]	Abbildung
404.81.909	Metallventil für Alufelgen	TR 542	n.v.	9.7	32.0	14.0	gerade	V8
404.81.905	Metallventil für Alufelgen	40 MS	n.v.	9.7	40.0	14.0	gerade	V6
404.81.906	Metallventil für Alufelgen	54 MS	n.v.	9.7	54.0	14.0	gerade	V5
404.81.904	Metallventil für Alufelgen	60 MS	n.v.	9.7	60.0	14.0	gerade	V4
404.81.903	Metallventil für Alufelgen	TR 545 D	n.v.	9.7	66.0	14.0	60	V2
404.81.900	Metallventil für Alufelgen	70-7 MS	n.v.	9.7	70.0	14.0	7	V1
404.81.901	Metallventil für Alufelgen	70-27 MS	n.v.	9.7	70.0	14.0	27	V3
404.81.908	Metallventil für Alufelgen	74 -27 MS	n.v.	9.7	70.0	14.0	27	V9
404.81.902	Metallventil für Alufelgen	60-45 MS	n.v.	9.7	70.0	14.0	45	V2
404.81.907	Metallventil für Alufelgen	83 MS	n.v.	9.7	83.0	14.0	gerade	V7



V5



V6



V7



V8



V9



Artikel-Nr.	Felgengröße	Anschluss	Bolzenloch-ausführung	Zentrierung	ET	HMA	Ventilposition
309.63.006	6.00 x 17.5	10/176/225	Ø 26, M20/M22	MZ	+122.5	135.5	ILV
309.63.014	6.75 x 17.5	6/161/205	B2	BMZ	0		ALV
309.63.008	6.75 x 17.5	10/176/225	Ø 26, M20/M22	MZ	+125	138	ILV
309.63.013	6.75 x 17.5	10/176/225	B33	BMZ	+130	143	ILV
309.63.065	7.50 x 19.5	8/221/275	Ø 26, M20/M22	MZ	+140	153	ALV
309.63.060	7.50 x 19.5	10/176/225	B33	BMZ	+138.5	151	ALV
309.63.017	7.50 x 22.5	10/281/335	Ø 26, M20/M22	MZ	+147	160	ALV
309.63.016	7.50 x 22.5	10/281/335	Ø 26, M20/M22	MZ	+147	160	ALV
309.63.018	8.25 x 22.5	10/281/335	Ø 26, M20/M22	MZ	+151	165	ALV
309.63.021	9.00 x 22.5	10/281/335	B33	BMZ	+161	175	ALV
309.63.022	9.00 x 22.5	10/281/335	B33	BMZ	+161	175	ALV
309.63.035	11.75 x 22.5 H	10/281/335	Ø 26, M20/M22	MZ	0		ALV
309.63.036	11.75 x 22.5 H	10/281/335	Ø 26, M20/M22	MZ	+135		ALV
309.63.041	11.75 x 22.5 H	10/281/335	Ø 26, M20/M22	MZ	+120		ALV
309.63.042	11.75 x 22.5 H	10/281/335	Ø 26, M20/M22	MZ	+120		ALV
309.63.033	11.75 x 22.5 H	10/281/335	B33	BMZ	0		ALV
309.63.034	11.75 x 22.5 H	10/281/335	B33	BMZ	0		ALV
309.62.060	14.00 x 22.5 H2	10/281/335	B33	BMZ	0		ALV





Tragfähigkeit [kg]		Geschwindigkeit [km/h]		Gewicht [kg]	Farbe	Bemerkung	Abbildung
Einzel	Zwilling	Einzel	Zwilling				
2725	2725	100	100	26,50	silber	mit Ventil	B1
2500		140		26,50	silber	mit Ventil	B9
2750	2750	140	140	27,50	silber	mit Ventil	B1
2757	2757	110	110	27,50	silber	mit Ventil	B1
2900	2900	90	90	34,20	silber	mit Ventil	B2
2900	2900	90	90	34,20	silber	mit Ventil	B4
3250	3250	100	100	37,00	silber	mit Ventil	B4
3250	3250	100	100	37,00	schwarz	mit Ventil	B8
3500	3500	100	100	37,50	silber	mit Ventil	B4
4000	4000	100	100	40,00	silber	mit Ventil	B4
4000	4000	100	100	40,00	schwarz	mit Ventil	B8
5000		100		43,50	silber	mit Ventil	B5
5000		100		42,50	silber	mit Ventil	B7
5000		100		43,50	silber	mit Ventil	B7
5000		100		42,50	schwarz	mit Ventil	B10
5000		100		42,50	schwarz	mit Ventil	B10
5000		100		43,50	silber	mit Ventil	B5
5500		130		56,42	silber	mit Ventil	B6

BZ: bolzenzentriert · BMZ: bolzenmittenzentriert · MZ: mittenzentriert · ALV: außenliegendes Ventil · ILV: innenliegendes Ventil





Artikel-Nr.	Felgenreöße	Anschluss	Bolzenloch- ausführung	Zentrierung	ET	HMA	Ventilposition
300.60.041	6.5 - 15	6/161/205	A2	BZ	-30		ALV
330.60.030	6.5 - 15	6/161/205	A2	BZ	0		ALV
300.60.020	6.5 - 15	6/161/205	B2	BZ	+124		ILV
300.60.040	6.5 - 15	10/176/225	B3	BZ	+124		ILV
330.60.031	6.00 - 16	6/161/205	A2	BZ	0		ILV
330.60.098	6.00 x 17.5	6/161/205	A2	BZ	0		ALV
330.60.048	6.00 x 17.5	6/161/205	A2	BZ	+70		ILV
330.60.060	6.75 x 17.5	6/161/205	A2	BZ	0		ALV
330.60.058	6.75 x 17.5	6/161/205	A2	BZ	+45		ALV
330.60.065	6.75 x 17.5	6/161/205	B2	BZ	+126	138	ILV
330.60.053	6.75 x 17.5	8/221/275	A2	BZ	0		ALV
330.60.059	6.75 x 17.5	8/221/275	B2	BZ	+129	141	ILV
330.60.063	6.75 x 17.5	8/221/275	B2	BZ	+118	130	ILV
330.60.069	6.75 x 17.5	8/221/275	Ø 26, M20/M22	MZ	+130	142	ILV
330.60.068	6.75 x 17.5	10/176/225	A3	BZ	-40		ALV
391.60.055	6.75 x 17.5	10/176/225	B33	BMZ	+133	145	ILV
330.60.086	6.75 x 17.5	10/176/225	B33	BMZ	+123		ILV
330.60.095	7.50 x 19.5	6/161/205	A2	BZ	0		ALV
312.67.876	7.50 x 19.5	8/221/275	A33	BMZ	0		ALV
312.67.872	8.25 x 19.5	6/161/205	A2	BZ	0		ALV
312.67.871	8.25 x 19.5	8/221/275	A2	BZ	0		ALV
312.67.874	8.25 x 19.5	8/221/275	A33	BMZ	0		ALV
312.67.875	8.25 x 19.5	10/176/225	A33	BMZ	0		ALV
312.67.881	11.75 x 19.5	6/161/205	A2	BZ	0		ALV
312.67.879	11.75 x 19.5	8/221/275	A2	BZ	0		ALV
312.67.878	11.75 x 19.5	8/221/275	A2	BZ	0		ALV
312.67.883	11.75 x 19.5	10/176/225	B3	BZ	0		ALV
312.67.913	14.00 x 19.5	10/281/335	Ø 26, M20/M22	MZ	+120		ILV





Tragfähigkeit [kg]		Geschwindigkeit [km/h]		Gewicht [kg]	Farbe	Zusatzinfo	Art.-Nr. Jantsa	Abbildung
Einzel	Zwilling	Einzel	Zwilling					
2300		100		28,50	silber	mehrteilig	65196	J2
2300		105		28,50	silber	mehrteilig	65160	J3
2300		105		25,40	silber	mehrteilig	65161	J1
2650		105		29,60	silber	mehrteilig	65164	J9
1500		100		21,00	silber	mehrteilig	60500	J3
2725		100		22,00	silber	voll verschweißt	600126	J10
2400		110		21,50	silber		600738	J10
2750		105		25,20	silber		675128	J10
2750		100		24,00	silber		675821	J19
2725	2725	100	100	26,50	silber		675167	J6
2750		100		24,00	silber		675708	J4
3000	3000	100	100	24,00	silber		675715	J5
2050	2050	100	100	24,00	silber		675824	J5
2750	2750	100	100	24,00	silber		675703	J8
3000		100		26,50	silber		675833	J7
2575	2575	100	100	24,00	silber		675168	J16
3000		100		24,00	silber		675772	J16
2725		100		34,00	silber		750316	J10
3000		100		34,00	silber		750195	J4
3350		100		28,00	silber		825300	J10
3350		100		28,00	silber		825118	J4
3350		100		28,00	silber		825312	J4
3350		100		35,00	silber		825320	J20
4000		100		41,50	silber		111952	J10
3850		100		41,00	silber		111975	J4
3850		100		41,00	rot	RAL 3000	111975	-
4500		100		41,00	silber		111992	J20
4500		100		38,50	silber		141994	J16

BZ: bolzenzentriert · BMZ: bolzenmittenzentriert · MZ: mittenzentriert · ALV: außenliegendes Ventil · ILV: innenliegendes Ventil





8 842 61



Artikel-Nr.	Felgenreöße	Anschluss	Bolzenloch- ausführung	Zentrierung	ET	HMA	Ventilposition
330.60.150	7.5 - 20	6/161/205	A2	BZ	0		ALV
330.60.180	18.00 x 20.5	10/281/335	B3	BZ	-50		ALV
330.60.181	18.00 x 20.5	10/281/335	B3	BZ	0		ALV
330.60.190	7.50 x 22.5	8/221/275	A33	BMZ	0		ALV
330.60.240	9.00 x 22.5	8/221/275	A2	BZ	0		ALV
330.60.250	9.00 x 22.5	10/281/335	A3	BZ	0		ALV
330.60.266	11.75 x 22.5	8/221/275	B2	BZ	-60		ALV
330.60.267	11.75 x 22.5	8/221/275	A3	BZ	0		ALV
330.60.255	11.75 x 22.5	8/221/275	B3	BZ	0		ALV
330.60.274	11.75 x 22.5	10/281/335	A3	BZ	0		ALV
330.60.254	11.75 x 22.5	10/281/335	B33	BMZ	+34		ALV
330.60.269	11.75 x 22.5	10/281/335	Ø 26, M20/M22	MZ	0		ALV
330.60.268	11.75 x 22.5	10/281/335	Ø 26, M20/M22	MZ	+120		ALV
330.60.306	14.00 x 22.5	8/221/275	A2	BZ	0		ALV
330.60.312	14.00 x 22.5	10/281/335	B33	BMZ	0		ALV
330.60.305	14.00 x 22.5	10/281/335	B33	BMZ	0		ALV





Tragfähigkeit [kg]		Geschwindigkeit [km/h]		Gewicht [kg]	Farbe	Zusatzinfo	Art.-Nr. Jantsa	Abbildung
Einzel	Zwilling	Einzel	Zwilling					
3400		100		54,00	silber	mehrteilig	75421	J17
7100		80		60,00	silber		205190	J13
7100		80		60,00	silber		205186	J13
3250		100		35,00	silber		750209	J4
3650		100		40,00	silber		900246	J4
3650		100		40,00	silber		900260	J21
4650		80		52,00	silber		117720	J11
4500		100		52,00	silber	HW80	117579	J4
4500		100		52,00	silber		117571	J18
4500		100		52,00	silber	VS H	117696	J18
5000		100		52,00	silber	verstärkt	117721	J16
4500		130		52,00	silber		117667	J15
4500		130		52,00	silber		117665	J15
5250		100		50,50	silber		140216	J4
4500		110		61,00	silber	VSV	140277	J12
5600		100		53,00	silber		140203	J12

BZ: bolzenzentriert · BMZ: bolzenmittenzentriert · MZ: mittenzentriert · ALV: außenliegendes Ventil · ILV: innenliegendes Ventil
 VS H: Ventilschutz halbrund · VS V: Ventilschutz voll



J13



J14



J15



J20



J21



8 842 61



Artikel-Nr.	Felgenreöße	Anschluss	Bolzenloch- ausführung	Zentrierung	ET	HMA	Ventilposition
314.59.997	6.00 x 17.5 H	6/161/205	Ø 21, M18	MZ	+120	131	ALV
314.59.998	6.00 x 17.5 H	6/161/205	Ø 21, M18	MZ	+114	125	ALV
314.59.999	6.00 x 17.5	10/176/225	A33	BMZ	+122.5	133	ILV
314.60.004	6.75 x 17.5	6/161/205	A2	BMZ	0		ALV
314.60.003	6.75 x 17.5 H	6/202/245	B2	BMZ	+129	139	ALV
314.60.005	6.75 x 17.5 H	6/202/245	Ø 21, M18	MZ	+133.5	145	ALV
314.60.002	6.75 x 17.5 H	8/221/275	Ø 24, M20	MZ	+130.5	140	ALV
314.60.000	6.75 x 17.5	10/176/225	A33	BMZ	+129.5	140	ILV
314.60.046	6.75 x 19.5	8/221/275	Ø 24, M20	MZ	+133.1	145	ALV
314.60.045	6.75 x 19.5	8/221/275	B33	BMZ	+133.1	145	ALV
314.60.040	7.50 x 19.5 H	8/221/275	Ø 26, M22	MZ	+138.1	150	ALV
314.60.041	7.50 x 19.5	8/221/275	B33	BMZ	+144.1	156	ALV
314.60.043	7.50 x 19.5	10/176/225	A33	BMZ	+138	151	ALV
314.60.054	8.25 x 19.5	8/221/275	Ø 24, M20	MZ	+157	170	ALV
314.60.049	8.25 x 19.5	8/221/275	Ø 26, M22	MZ	+65		ALV
314.60.006	11.75 x 19.5	8/221/275	Ø 26, M22	MZ	0		ALV
314.60.009	11.75 x 19.5	10/281/335	Ø 26, M22	MZ	0		ALV
314.60.008	11.75 x 19.5	10/281/335	Ø 26, M22	MZ	+120		ALV
340.60.245	14.00 x 19.5	8/221/275	Ø 26, M22	MZ	0		ALV
314.60.010	14.00 x 19.5	10/281/335	Ø 26, M22	MZ	+120		ALV
314.60.018	6.75 x 22.5	8/221/275	Ø 24, M20	MZ	+132.5	143	ILV
314.60.026	7.50 x 22.5	8/221/275	Ø 24, M20	MZ	+147.5	160	ALV
314.60.021	7.50 x 22.5	10/281/335	Ø 26, M22	MZ	+152.5	165	ALV
314.60.020	7.50 x 22.5	10/281/335	Ø 26, M22	MZ	+147.5	160	ALV
314.60.032	8.25 x 22.5	10/281/335	Ø 26, M22	MZ	+152.5	165	ALV





Tragfähigkeit [kg]		Geschwindigkeit [km/h]		Gewicht kg	Farbe	Bemerkung	Art.-Nr. Accuride	Abbildung
Einzel	Zwilling	Einzel	Zwilling					
1850	1750	130	130	19,50	silber	mit Ventil	SRB140000E-HB0A200	S2
1850	1750	130	130	20,50	silber	mit Ventil	SRB1400500-HB0A200	S2
3150	3000	130	130	24,20	silber	mit Ventil	SRB1401500-HB0B200	S3
2725		130		23,00	silber	mit Ventil	SRB1401900-HB0B200	S1
2000	1900	130	130	20,90	silber	mit Ventil	SRB3500500-HB0A200	S1
2360	2180	130	130	21,00	silber	mit Ventil	SRB1400900-HB0A200	S1
2360	2180	130	130	21,00	silber	mit Ventil	SRB1401100-HB0A200	S4
3150	3000	130	130	25,00	silber	mit Ventil	SRB1401700-HB0B200	S3
2500	2360	130	130	23,80	silber	mit Ventil	SRB353660E-HB0A200	S4
2500	2360	130	130	23,80	silber	mit Ventil	SRB353670E-HB0B200	S4
2800	2650	130	130	25,80	silber	mit Ventil	SRB3536800-HB0B200	S4
3000	2800	130	130	28,00	silber	mit Ventil	SRB3537000-HB0B200	S4
2725		130		28,00	silber	mit Ventil	SRB355520E-HB0A200	S5
3150	2900	130	130	29,00	silber	mit Ventil	SRB353710E-HB0B200	S4
3350		130		25,40	silber	mit Ventil	SRB355550E-HB0B200	S6
4500		130		37,60	silber	mit Ventil	SRB3542300-HB0B200	S7
4500		130		38,00	silber	mit Ventil	SRB3542100	S9
4500		130		38,80	silber	mit Ventil	SRB3542200	S8
4500		130		42,20	silber	mit Ventil	SRB3542600-HB0D200	S7
4500		130		43,00	silber	mit Ventil	SRB3542500	S8
2800	2650	130	130	34,50	silber	mit Ventil	SRB151300E	S4
3250	2900	130	130	35,50	silber	mit Ventil	KPB1512400-HB0A200	S4
3750	3250	130	130	35,00	silber	mit Ventil	KPB1510700	S10
3750	3150	130	130	34,50	silber	mit Ventil	KPB151210E	S10
3750	3250	130	130	33,50	silber	mit Ventil	KPB1509800	S10

BZ: bolzenzentriert · BMZ: bolzenmittenzentriert · MZ: mittenzentriert · ALV: außenliegendes Ventil · ILV: innenliegendes Ventil





8 842 61



Artikel-Nr.	Felgenreöße	Anschluss	Bolzenloch- ausführung	Zentrierung	ET	HMA	Ventilposition
314.60.050	9.00 x 22.5 H	10/281/335	B33	BMZ	+160.8	175	ALV
314.60.053	9.00 x 22.5	10/281/335	Ø 26, M22	MZ	+162.5	175	ALV
314.60.052	9.00 x 22.5 H	10/281/335	Ø 26, M22	MZ	+160.8	175	ALV
314.60.070	9.75 x 22.5 H	10/281/335	Ø 26, M22	MZ	+162.5	175	ALV
314.60.201	11.75 x 22.5 H	8/221/275	Ø 24, M20	MZ	+120		ALV
314.60.100	11.75 x 22.5	10/281/335	B33	BMZ	0		ALV
314.60.110	11.75 x 22.5 H	10/281/335	Ø 26, M22	MZ	+135		ALV
314.60.200	11.75 x 22.5	10/281/335	Ø 26, M22	MZ	+120		ALV
314.60.210	13.00 x 22.5	10/281/335	Ø 26, M22	MZ	0		ALV
314.60.211	13.00 x 22.5	10/281/335	Ø 26, M22	MZ	+120		ALV
314.60.215	14.00 x 22.5	10/281/335	Ø 26, M22	MZ	0		ALV
314.60.245	15.00 x 22.5 H	10/281/335	Ø 26, M22	MZ	0		ALV
314.60.260	15.00 x 22.5 H	10/281/335	Ø 26, M22	MZ	+120		ALV



S10



S11



S12



S13



Tragfähigkeit [kg]		Geschwindigkeit [km/h]		Gewicht kg	Farbe	Bemerkung	Art.-Nr. Accuride	Abbildung
Einzel	Zwilling	Einzel	Zwilling					
4500	3750	130	130	43,00	silber	mit Ventil	KPB1502900	S10
4000	3350	130	130	36,50	silber	mit Ventil	KPB1509900-HB0C200	S10
4500	3750	130	130	43,20	silber	mit Ventil	KPB1500500-LJ0B200	S10
3550	3150	130	130	40,00	silber	mit Ventil	KPB1508100-HB0B200	S10
3900		130		44,00	silber		KPB1103600	S13
5000		130		38,50	silber	mit Ventil	SRB505400	S11
5000		130		43,00	silber	mit Ventil	KPB1507300-HB0B200	S12
5000		130		38,50	silber	mit Ventil	KPB151460E	S12
5150		130		42,00	silber	mit Ventil	SRB3552700	S11
5150		130		48,00	silber	mit Ventil	SRB3552600	S12
5800		110		47,00	silber	mit Ventil	SRB3554900	S11
5300		130		46,00	silber	mit Ventil	SRB1110800-HB0B200	S11
5300		130		49,00	silber	mit Ventil	SRB1400300-HB0C200	S12

BZ: bolzenzentriert · BMZ: bolzenmittenzentriert · MZ: mittenzentriert · ALV: außenliegendes Ventil · ILV: innenliegendes Ventil





PREMIUM ALUMINIUMRÄDER

ACCURIDE FELGEN IM EINSATZ



Die Aluminiumfelgen des großen nordamerikanischen LKW-Alufelgen-Herstellers Accuride finden ihren Einsatz auf LKW, Anhängern, Bussen oder leichten Nutzfahrzeugen. Auf einem Lastzug gerechnet sparen die Alufelgen im Vergleich zu Stahlfelgen mehrere hundert Kilogramm Masse, somit kann mehr Nutzlast transportiert und die Radaufhänger und Stoßdämpfer geschont werden.

Außerdem erhöht sich somit die Lebensdauer von Reifen und Felgen und es kann mehr Treibstoff eingespart werden. Die zusätzlich hochwertige Veredelungsstufe XPC Alufelge - Polish + Accu-Shield sorgt mit der Premium Politur nicht nur für eine strahlende Oberfläche, die für geringeres Eigengewicht sorgt, sondern auch für eine problemlose Selbstreinigung.

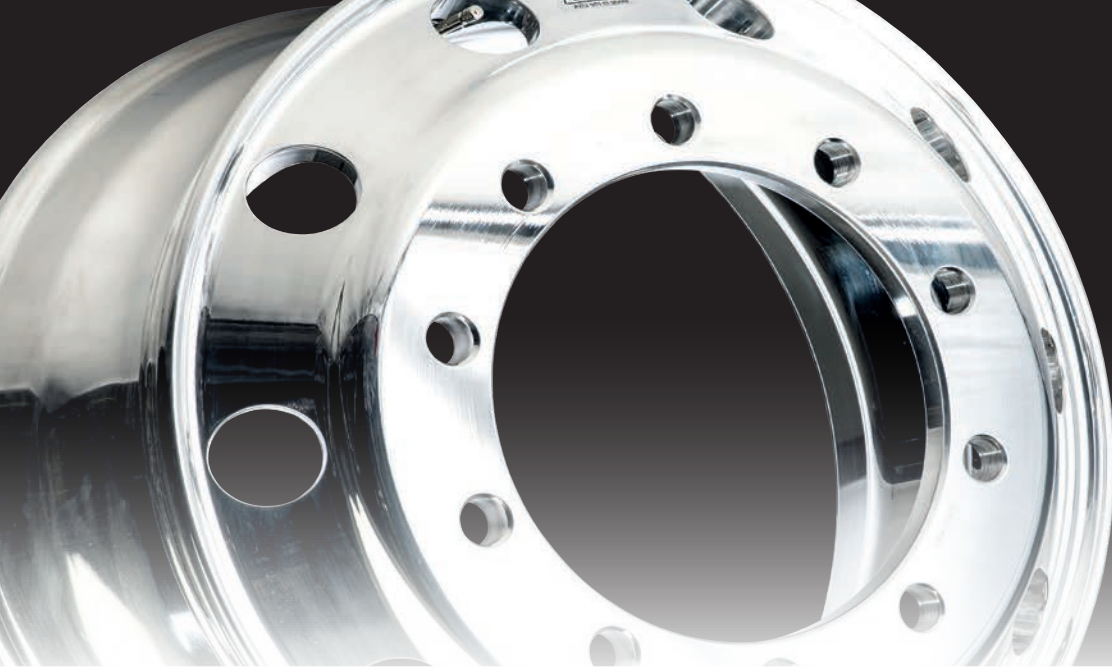

„Die alten Alufelgen sind immer sehr schnell angelaufen. Außerdem hat sich da Bremsstaub und jeder andere Dreck direkt reingefressen“, erinnert sich Vaak.

Früher mussten die matt gewordenen Felgen mit der Politurpaste aufgearbeitet werden. Heute werden die neuen Accuride Felgen dank ihrer patentierten Accushield-Beschichtung bereits bei der normalen LKW-Wäsche wieder blank.

Zuverlässigkeit und Expertise

Mit über 160 Jahren Erfahrung in der Herstellung bietet Accuride innovative Technologien, ein breites Produktportfolio und eine erstklassige Betriebsleistung - als zuverlässiger Partner für OEMs, Flotten und für alle Aftermarket-Kanäle.

Als ISO zertifiziertes Unternehmen bietet Accuride höchsten technologischen Standard und beste Qualität.



**Bis zu 5 Jahre
Herstellergarantie**

- ▶ mehr Effizienz durch mehr Zuladung und weniger Kraftstoffverbrauch
- ▶ europäischer Standard „Made in USA“
- ▶ geringer Verschleiß - lange Lebensdauer
- ▶ geschmiedet aus einem Werkstück, ermöglicht höhere Tragfähigkeit
- ▶ Zeitersparnis bei der Pflege durch Selbstreinigungseffekt
- ▶ nach ZWARP getestet



LLKW UND PKW - TRAILER FELGEN



SERVICE-PLUS BY BOHNENKAMP

Erhalten Sie direkten Zugriff
auf unseren Online-Shop



LLKW- und
PKW - Trailer folgen

Bohnenkamp
■ ■ ● Moving Professionals



Artikel-Nr.	Felgenreöße	Anschluss	ET	Ventil-position	Farbe	Fahrzeugtyp	Art.-Nr. Accuride	Abbildung
308.56.021	6 J x 15 H2	5/57/112	+47	ALV	silber	Caddy-Life/-Maxi	VO615036	K1
308.56.022	6 J x 15 H2	5/71/118	+68	ALV	silber	Jumper,Ducato,Boxer 06/06	FL615007	K2
308.56.050	5 J x 16 H2	6/130/170	+109	ALV	silber	Daily S2000 07/99	IV616011	K3
308.56.062	6 J x 16 H2	5/57/112	+50	ALV	silber	Caddy-Life/-Maxi 10/07	VO616021	K5
308.56.060	6 J x 16 H2	5/58/98	+37	ALV	silber	Doblo, Combo, 500 L	FL616007	K4
308.56.064	6 J x 16 H2	6/161/205	+124	ALV	silber	Daily S2000 07/99, Eurocago 01/02	IV616014	K6
308.56.080	6.5 J x 16 H2	5/65/120	+51	ALV	silber	Multivan, T5,T6, Shuttle	VO616016	K7
308.56.082	6.5 J x 16 H2	5/65/160	+60	ALV	silber	Tourneo-Transit-Custom	FO616009	K9
308.56.081	6.5 J x 16 H2	5/67/112	+52	ALV	silber	V-Klasse 05/14, Vito III	ME516027	K8
308.56.084	6.5 J x 16 H2	5/89/130	+66	ALV	silber	Movano, Master 04/10	RE616012	K10
308.56.086	6.5 J x 16 H2	6/74/125	+68	ALV	silber	Daily 2000 03/07,	IV616013	K12
308.56.085	6.5 J x 16 H2	6/84/130	+62	ALV	silber	Sprinter, Crafter 3,5 to	ME616013	K11

ALV: außenliegendes Ventil

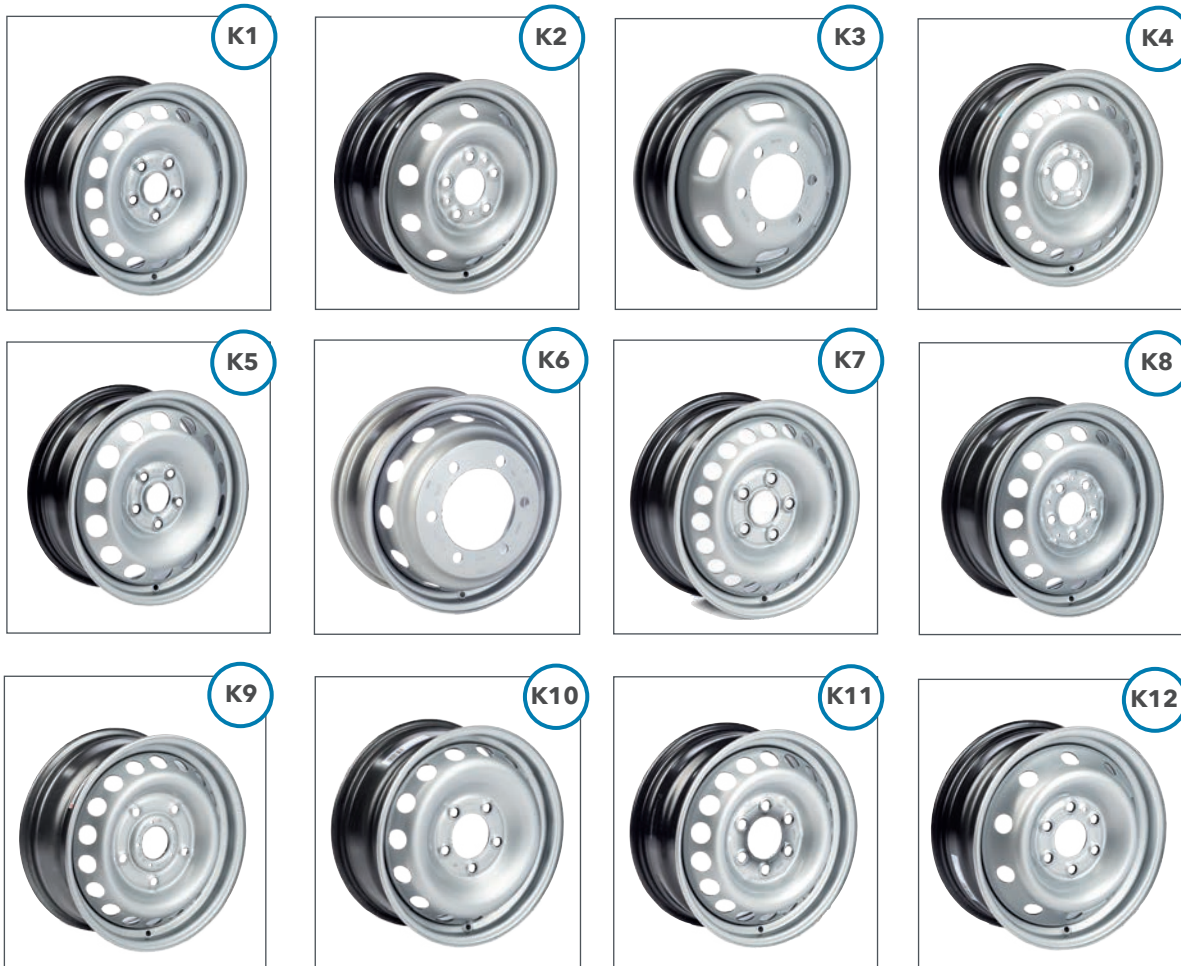

PKW - Trailer Felgen Aluminium

Artikel-Nr.	Felgenreiße	Anschluss	Bolzenloch- ausföhrung	Zentrie- rung	ET	Ventil- position	Trag- föhigkeit [kg]	Ge- schwin- digkeit [km/h]	Gewicht [kg]	Farbe	Abbil- dung
398.00.410	6 J x 10 H2	5/67/112	Ø16 mm, R12 (Kugel)	BZ	-4	ALV	750	140	4,45	silber	A1
398.00.010	6.0I x 10 H2	5/67.1/112	Ø15 mm, R12 (Kugel)	BZ	-4	ALV	1000	140	5,40	silber	A2
398.00.305	6 J x 13 H2	5/66.6/112	Ø14 mm, C60 (Kegel)	BZ	+30	ALV	900	140	5,90	silber	A3
398.00.420	6 J x 13 H2	5/67/112	Ø16 mm, R12 (Kugel)	BZ	+30	ALV	900	140	6,30	silber	A4
398.00.430	5.5 J x 14 H2	5/66.6/112	Ø15 mm, C60 (Kegel)	BZ	+30	ALV	950	140	7,40	silber	A4
398.00.437	6 J x 14 H2	5/66.6/112	Ø15 mm, C60 (Kegel)	BZ	+30	ALV	1000	140	7,60	schwarz poliert	A7
398.00.270	6.0 J x 15 H2	5/67/112	Ø15 mm, C60 (Kegel)	BZ	+31	ALV	900	140	8,15	silber	A6
398.00.440	6 J x 15 H2	5/67/112	Ø15 mm, C60 (Kegel)	BZ	+30	ALV	900	140	7,50	silber	A5

BZ: bolzenzentriert · ALV: außenliegendes Ventil



LLKW- und
PKW - Trailer Felgen



PKW-Trailer Felgen Stahl

Artikel-Nr.	Felgenreöße	Anschluss	Bolzenlochausführung	Zentrierung	ET	Ventilposition	Tragfähigkeit [kg]	Geschwindigkeit [km/h]	Gewicht [kg]	Farbe	Abbildung
306.55.010	2.50 A x 8	4/60/100	D12, Ø16 mm, R12 (Kugel)	BZ	0	ALV	425	130	1,45	silber	T1
396.00.306	2.50 A x 8 H2	4/63/100	Ø14.5 mm, C60 (Kegel)	BZ	0	ALV	345	140	3,65	silber	T2
396.00.280	2.50 A x 8 H2	4/85/115	Ø12.5 mm, C90 (Kegel)	BZ	0	ALV	345	140	1,40	silber	T2
306.55.020	3.00 D x 8	4/60/100	D12, Ø16 mm, R12 (Kugel)	BZ	0	ALV	300	100	1,80	silber	T1
306.55.030	5.50 A x 8	4/60/100	D12, Ø16 mm, R12 (Kugel)	BZ	0	ALV	350	100	2,65	silber	T3
396.00.064	5.50 A x 8 H	4/61/100	Ø15 mm, R12 (Kugel)	BZ	0	ALV	350	100	2,65	silber	T3
396.00.187	7.00 A x 8 H2	4/58.5/98	Ø13.5 mm, C60 (Kegel)	BZ	0	ALV	425	140	3,10	silber	T3
306.95.185	7.00 A x 8 H2	4/60/100	D12, Ø16 mm, R12 (Kugel)	BZ	0	ALV	425	100	2,95	silber	T3
308.55.001	3.00 B x 10	4/60/100	D12, Ø16 mm, R12 (Kugel)	BZ	0	ALV	375	100	3,95	silber	T4
396.00.289	3.50 B x 10 H2	4/60/100	Ø14.5 mm, C60 (Kegel)	BZ	0	ALV	500	140	3,56	silber	T5
308.55.007	6.00 I x 10 H2	4/60/100	D12, Ø16 mm, R12 (Kugel)	BZ	-4	ALV	500	140	6,45	silber	T3
308.55.000	6.00 I x 10 H2	5/67/112	G12, Ø16 mm, R12 (Kugel)	BZ	-4	ALV	750	140	6,55	silber	T6
396.00.283	6.00 I x 10 H2	5/67/112	Ø16 mm, C60 (Kegel)	BZ	+25	ALV	750	140	6,30	silber	T7
308.55.002	6.00 I x 10 H2	5/94/140	G1, Ø18.5 mm, R14 (Kugel)	BZ	-4	ALV	750	140	5,50	silber	T8
396.00.281	8.50 I x 10 H2	5/67/112	E12, Ø16 mm, R12 (Kugel)	BZ	-4	ALV	750	130	8,53	silber	T7
396.00.154	4.00 B x 12 H2	4/60/100	Ø13.5 mm, C60 (Kegel)	BZ	0	ALV	475	100	4,60	silber	T3
396.00.636	4.5 J x 12 H2	5/67/112	E12, Ø16 mm, R12 (Kugel)	BZ	+20	ALV	900	140	7,10	silber	T11
396.00.335	4.5 J x 12 H2	5/114.5/165.1	E43, Ø18.5 mm, C80 (Kegel)	BZ	0	ALV	900	140	7,10	silber	T20
396.00.635	5.5 J x 12 H2	5/67/112	E12, Ø16 mm, R12 (Kugel)	BZ	+30	ALV	900	140	5,90	silber	T11
396.00.314	5.5 J x 12 H2	5/114.5/165.1	E43, Ø18.5 mm, C80 (Kegel)	BZ	0	ALV	900	140	7,60	silber	T20
396.00.287	6 J x 12 H2	5/114.5/165.1	E43, Ø18.5 mm, C80 (Kegel)	BZ	0	ALV	900	140	8,00	silber	T20



Artikel-Nr.	Felgenreöße	Anschluss	Bolzenlochausführung	Zentrierung	ET	Ventilposition	Tragfähigkeit [kg]	Geschwindigkeit [km/h]	Gewicht [kg]	Farbe	Abbildung
396.00.305	7.00 l x 12 H2	5/67/112	E12, Ø16 mm, R12 (Kugel)	BZ	-4	ALV	950	140	7,88	silber	T6
308.10.273	7.00 l x 12 H2	5/67/112	E12, Ø16 mm, R12 (Kugel)	BZ	+30	ALV	900	140	7,80	silber	T9
308.10.270	7.00 l x 12 H2	5/67/112	E12, Ø16 mm, R12 (Kugel)	BZ	+10	ALV	900	140	7,80	silber	T9
396.00.659	4 J x 13 H2	4/57/100	E16, Ø15.5 mm, C60 (Kegel)	BZ	+30	ALV	525	140	5,20	silber	T10
396.00.309	4.5 J x 13 H2	4/57/100	E16, Ø15.5 mm, C60 (Kegel)	BZ	+30	ALV	600	140	6,20	silber	T10
396.00.667	4.5 J x 13 H2	4/58/98	Ø13 mm, C60 (Kegel)	BZ	+30	ALV	450	140	6,10	silber	T10
300.55.079	4.5 J x 13 H2	4/85/130	E1, Ø18.5 mm, R14 (Kugel)	BZ	+20	ALV	600	140	6,17	silber	T12
396.00.664	4.5 J x 13 H2	4/95.5/139.7	Ø14.5 mm, C60 (Kegel)	BZ	+25.4	ALV	765	140	6,55	silber	T12
300.45.101	4.5 J x 13 H2	5/67/112	E12, Ø16 mm, R12 (Kugel)	BZ	+30	ALV	625	140	6,10	silber	T11
300.55.081	5 J x 13 H2	5/66.5/112	E12, Ø16 mm, R12 (Kugel)	BZ	+30	ALV	900	140	7,87	silber	T11
316.55.080	5 J x 13 H2	5/66.6/112	E12, Ø16 mm, R12 (Kugel)	BZ	+33	ALV	725	140	6,90	silber	T14
396.00.301	5 J x 13 H2	5/67/112	Ø15.5 mm, C60 (Kegel)	BZ	+33	ALV	725	140	7,00	silber	T11
300.55.087	6 J x 13 H2	4/57/100	E16, Ø15.5 mm, C60 (Kegel)	BZ	+30	ALV	700	140	6,30	silber	T10
316.55.100	6 J x 13 H2	5/66.6/112	E12, Ø16 mm, R12 (Kugel)	BZ	+30	ALV	950	140	5,50	silber	T15
396.00.666	6 J x 13 H2	5/67/112	E12, Ø16 mm, R12 (Kugel)	BZ	+30	ALV	950	140	9,00	silber	T11
396.00.321	6 J x 13 H2	5/114.5/165.1	E43, Ø18.5 mm, C80 (Kegel)	BZ	+7	ALV	950	140	9,00	silber	T20

BZ: bolzenzentriert - ALV: außenliegendes Ventil

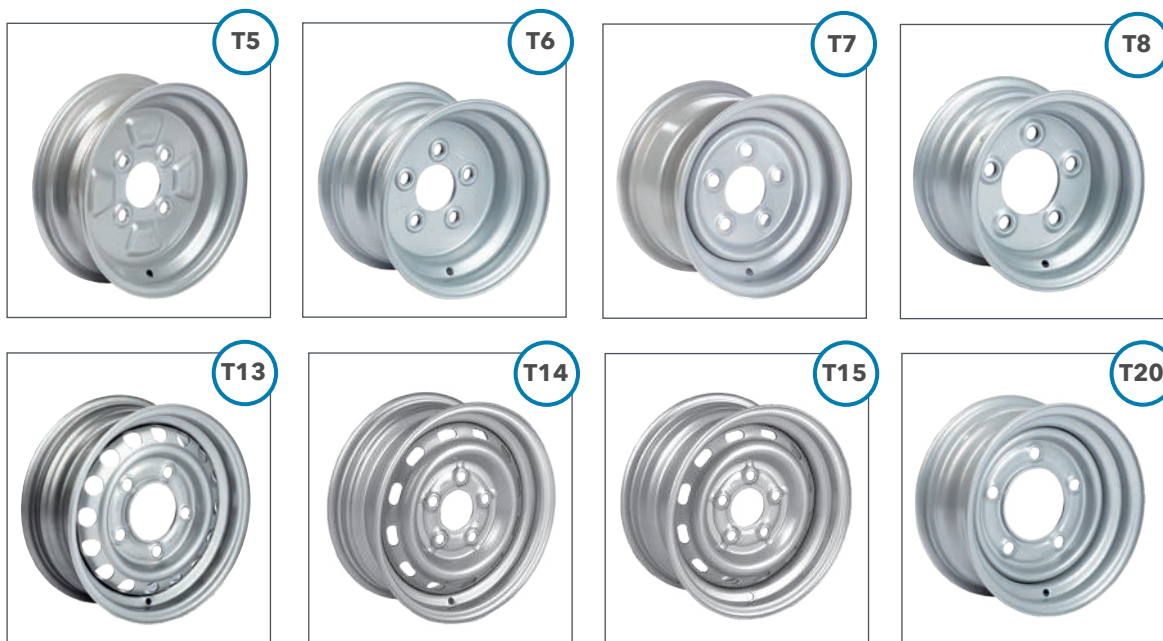



PKW-Trailer Felgen Stahl

Artikel-Nr.	Felgenreöße	Anschluss	Bolzenlochausführung	Zentrierung	ET	Ventilposition	Tragfähigkeit [kg]	Geschwindigkeit [km/h]	Gewicht [kg]	Farbe	Abbildung
396.00.671	5.5 J x 14 H2	4/57/100	E16, Ø15.5 mm, C60 (Kegel)	BZ	+30	ALV	750	140	9,50	silber	T10
396.00.672	5.5 J x 14 H2	5/67/112	E12, Ø16 mm, R12 (Kugel)	BZ	+30	ALV	950	140	9,40	silber	T11
398.00.449	5.5 J x 14 H2	5/94/140	E1, Ø18.5 mm, R14 (Kugel)	BZ	0	ALV	950	140	9,95	silber	T13
398.00.450	6 J x 14 H2	6/161/205	E2, Ø21.5 mm, R16 (Kugel)	BZ	-5	ALV	1250	140	10,30	silber	T17
398.00.445	6 J x 14 H2	6/161/205	E2, Ø21.5 mm, R16 (Kugel)	BZ	0	ALV	1250	140	9,20	silber	T17
396.00.303	5.5 J x 15 H2	5/66/112	Ø17 mm, R12 (Kugel)	BZ	+30	ALV	900	140	10,60	silber	T18
308.55.302	6 J x 15 H2	5/66.6/112	E12, Ø16 mm, R12 (Kugel)	BZ	+30	ALV	900	140	9,90	silber	T18
316.10.095	6 J x 15 H2	6/161/205	A2, Ø21.5 mm, R16 (Kugel)	BZ	0	ALV	1285	100	12,00	silber	T17
396.00.328	5 J x 16 H2	5/115/165.1	E43, Ø18.5 mm, C80 (Kegel)	BZ	+39,7	ALV	900	140	11,20	silber	T18
300.55.405	6 J x 16 H2	5/66.5/112	E12, Ø16 mm, R12 (Kugel)	BZ	+30	ALV	900	140	11,50	silber	T19
308.55.340	6 J x 16 H2	6/161/205	A2, Ø21.5 mm, R16 (Kugel)	BZ	-5	ALV	1250	140	13,20	silber	T17

BZ: bolzenzentriert ALV: außenliegendes Ventil



PKW - Trailer Felgen Aluminium/Stahl - Zubehör



Artikel-Nr.	Beschreibung 1	Beschreibung 2	Design	Abbildung
398.99.315	Radschraube für Stahlfelgen	Kugelbund, M12 x 1.5 x 25 mm		1
398.99.415	Radschraube für Stahlfelgen	Kegelbund, M12 x 1.5 x 24 mm		2
398.99.310	Radschraube für Alufelgen	Kugelbund, M12 x 1.5 x 28 mm		1
398.99.400	Radschraube für Alufelgen	Kegelbund, M12 x 1.5 x 28 mm		2
398.99.408	Nabenkappe 60 mm	für Alufelge TR1, TR12	poliert	8
398.99.402	Nabenkappe 60 mm	für Alufelge TR3, TR8	silber	5
398.99.407	Nabenkappe 60 mm	für Alufelge BK01, BK8	Flamme	6
398.99.574	Nabenkappe 60 mm	für Alufelge BK01, BK8	Car Fashion	7
398.99.001	Nabenkappe 65 mm	für Alufelge BK510, BK513, BK514	BK TRAILER	3
398.99.002	Nabenkappe 65 mm	für Alufelge BK510, BK513, BK514	BOKA TRAILER LINE	4



Radschraube



Radschraube



Nabenkappe für Alufelgen BK 510, BK 513, BK514



Nabenkappe für Alufelgen TR3, TR8



Nabenkappe für Alufelgen BK01, BK8

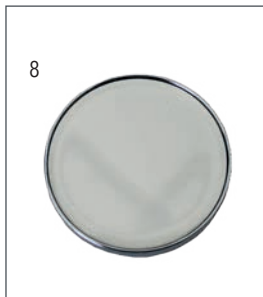

Nabenkappe für Alufelgen TR1, TR12

nokian[®]
TYRES

WINDPOWER

Get Your Job Done

 **SAILUN**
TYRE



RÄDER



SERVICE-PLUS BY BOHNENKAMP

Erhalten Sie direkten Zugriff
auf unseren Online-Shop



Bohnenkamp
■ ■ ● Moving Professionals



LKW Räder mit Stahl-Felge

nokian[®]
TYRES



TL/
TT



M+S



Artikel-Nr.	Größe	Last-/ Speed-Index	TT/TL	Profil	M+S	3-PMSF	Tragfähigkeit kpl. Rad kg / km/h
599.67.787	385/55 R 22.5	160 K (158 L)	TL	Hakka Truck 844	x	x	4500 / 110
599.67.786	385/55 R 22.5	160 K (158 L)	TL	Hakka Truck 844	x	x	4500 / 110
599.19.102	385/65 R 22.5	160 K (158 L)	TL	E-Truck Trailer	x	x	4500 / 110
599.19.101	385/65 R 22.5	160 K (158 L)	TL	E-Truck Trailer	x	x	4500 / 110

Premium - Verbindung





Felge

Größe	Anschluss	ET	Bolzenloch- ausführung	Zentrierung	Ventil- position	Farbe	Rollwider- stand	Nass- haftung	Rollgeräusch dB	Level
11.75 x 22.5	10/281/335	0	B33	BMZ	ALV	silber	D	B	72	B
11.75 x 22.5	10/281/335	+120	Ø 26, M22	MZ	ALV	silber	D	B	72	B
11.75 x 22.5	10/281/335	0	B33	BMZ	ALV	silber	C	B	70	A
11.75 x 22.5	10/281/335	+120	Ø 26, M22	MZ	ALV	silber	C	B	70	A

BMZ: bolzenmittenzentriert · MZ: mittenzentriert · ALV: außenliegendes Ventil

**Alle Marken kombinierbar
als individuelles Komplettrad**



+



**Viele weitere Möglichkeiten
erhalten Sie gerne auf Anfrage!**



LKW Räder mit Stahl-Felge

WINDPOWER

Get Your Job Done



TL/
TT



M+S



Artikel-Nr.	Größe	Last-/ Speed-Index	TT/TL	Profil	M+S	3-MSF	Tragfähigkeit kpl. Rad kg / km/h
599.67.619	215/75 R 17.5	135 / 133 J	TL	WTL 31	x	x	2180 / 100
599.67.604	215/75 R 17.5	135 / 133 J	TL	WTL 31	x	x	2180 / 100
599.67.578	215/75 R 17.5	135 / 133 J	TL	WTL 31	x	x	2180 / 100
599.67.617	235/75 R 17.5	143 / 141 J	TL	WTL 31	x	x	2500 / 100
599.67.620	235/75 R 17.5	143 / 141 J	TL	WTL 31	x	x	2725 / 100
599.67.609	235/75 R 17.5	143 / 141 J	TL	WTL 31	x	x	2725 / 100
599.67.606	245/70 R 17.5	143 / 141 J (146 / 146 F)	TL	WTR 69	x	x	2725 / 100
599.67.807	265/70 R 19.5	143 / 141 J	TL	WGC 28	x	x	2725 / 100
599.67.748	285/70 R 19.5	150 / 148 J	TL	WTR 69	x	x	3350 / 100
599.67.741	285/70 R 19.5	150 / 148 J	TL	WTR 69	x	x	3350 / 100
599.67.791	385/55 R 22.5	158 L (160 K)	TL	WGC 28	x	x	4500 / 100
599.67.796	385/55 R 22.5	158 L (160 J)	TL	WTR 69	x	x	4500 / 100
599.19.089	385/65 R 22.5	160 K	TL	RE Power WP Truck	x	x	4500 / 110
599.67.879	385/65 R 22.5	160 K (158 L)	TL	WGC 28	x	x	4500 / 110
599.19.096	385/65 R 22.5	160 K (158 L)	TL	WTR 69	x	x	4500 / 80
599.19.082	385/65 R 22.5	160 K (158 L)	TL	WTR 69	x	x	4500 / 100
599.19.091	385/65 R 22.5	160 K (158 L)	TL	WTR 69	x	x	4500 / 100
599.19.080	385/65 R 22.5	160 K (158 L)	TL	WTR 69	x	x	4500 / 110
599.67.885	385/65 R 22.5	160 K (158 L)	TL	WTR 69	x	x	4500 / 100
599.67.886	385/65 R 22.5	164 K (158 L)	TL	WTR 69+	x	x	5000 / 100
599.67.917	425/65 R 22.5	165 K	TL	WGC 28	x	x	4500 / 80
599.67.914	425/65 R 22.5	165 K	TL	WGC 28	x	x	5150 / 100
599.67.915	425/65 R 22.5	165 K	TL	WTR 69	x	x	5150 / 100
599.67.968	445/65 R 22.5	169 K	TL	WGC 28	x	x	4500 / 80
599.67.967	445/65 R 22.5	169 K	TL	WGC 28	x	x	5600 / 100
599.67.974	445/65 R 22.5	169 K	TL	WGC 28	x	x	5150 / 100
599.67.965	445/65 R 22.5	169 K	TL	WTR 69	x	x	5600 / 100



Felge

Größe	Anschluss	ET	Bolzenloch- ausführung	Zentrie- rung	HMA	Ventil- position	Farbe	Rollwider- stand	Nass- haftung	Rollgeräusch dB	Level
6.75 x 17.5	6/161/205	0	B2	BMZ		ALV	silber	D	C	71	A
6.75 x 17.5	6/161/205	+126	B2	BZ	138	ILV	silber	D	C	71	A
6.75 x 17.5	10/176/225	+130	B33	BMZ	143	ILV	silber	D	C	71	A
6.75 x 17.5	6/161/205	0	B2	BMZ		ALV	silber	D	B	69	A
6.75 x 17.5	6/161/205	+126	B2	BZ	138	ILV	silber	D	B	69	A
6.75 x 17.5	10/176/225	+130	B33	BMZ	143	ILV	silber	D	B	69	A
6.75 x 17.5	6/161/205	0	A2	BZ		ALV	silber	D	C	71	A
8.25 x 19.5	8/221/275	0	A2	BZ		ALV	silber	E	B	74	B
8.25 x 19.5	6/161/205	0	A2	BZ		ALV	silber	D	C	72	B
8.25 x 19.5	8/221/275	0	A33	BMZ		ALV	silber	D	C	72	B
11.75 x 22.5	10/281/335	0	B33	BMZ		ALV	silber	D	B	74	B
11.75 x 22.5	10/281/335	0	B33	BMZ		ALV	silber	C	C	72	B
11.75 x 22.5	10/281/335	0	B33	BMZ		ALV	silber				
11.75 x 22.5	10/281/335	0	B33	BMZ		ALV	silber	C	C	74	B
11.75 x 22.5	8/221/275	0	A2	BZ		ALV	silber	C	C	72	B
11.75 x 22.5	10/281/335	0	A3	BZ		ALV	silber	C	C	72	B
11.75 x 22.5	10/281/335	0	B33	BMZ		ALV	silber	C	C	72	B
11.75 x 22.5	10/281/335	0	B33	BMZ		ALV	silber	C	C	72	B
11.75 x 22.5	10/281/335	+120	Ø 26, M20/M22	MZ		ALV	silber	C	C	72	B
11.75 x 22.5	10/281/335	0	B33	BMZ		ALV	silber	B	C	72	B
14.00 x 22.5	10/281/335	0	A3	BZ		ALV	silber	C	C	74	B
14.00 x 22.5	10/281/335	0	B33	BMZ		ALV	silber	C	C	74	B
14.00 x 22.5	10/281/335	0	B33	BMZ		ALV	silber	C	D	71	A
14.00 x 22.5	10/281/335	0	A3	BZ		ALV	silber	C	C	74	B
14.00 x 22.5	10/281/335	0	B33	BMZ		ALV	silber	C	C	74	B
14.00 x 22.5	10/281/335	-50	B33	BMZ		ALV	silber	C	C	74	B
14.00 x 22.5	10/281/335	0	B33	BMZ		ALV	silber	C	B	73	B

BZ: bolzenzentriert · BMZ: bolzenmittenzentriert · MZ: mittenzentriert · ALV: außenliegendes Ventil · ILV: innenliegendes Ventil



LKW Räder mit Stahl-Felge



Artikel-Nr.	Größe	Last-/ Speed-Index	TT/TL	Profil	M+S	3-PMSF	Tragfähigkeit kpl. Rad kg / km/h
599.67.549	215/75 R 17.5	135 / 133 L	TL	SAR1	x	x	2180 / 120
599.67.550	215/75 R 17.5	135 / 133 L	TL	SAR1	x	x	2180 / 100
599.67.551	215/75 R 17.5	135 / 133 L	TL	SAR1	x	x	2180 / 120
599.67.552	235/75 R 17.5	143 / 141 L	TL	SAR1	x	x	2725 / 100
599.67.553	245/70 R 17.5	143 / 141 J	TL	SAR1	x	x	2725 / 100
599.67.635	265/70 R 19.5	143 / 141 J	TL	SAR1	x	x	2725 / 100
599.67.637	265/70 R 19.5	143 / 141 J	TL	SAR1	x	x	2725 / 100
599.67.636	265/70 R 19.5	143 / 141 J	TL	STM1	x	x	2725 / 100
599.67.638	285/70 R 19.5	150 / 148 K	TL	SAR1	x	x	3350 / 100
599.67.639	285/70 R 19.5	150 / 148 K	TL	SAR1	x	x	3350 / 100
599.67.642	435/50 R 19.5	160 J	TL	STL1	x	x	2000 / 70
599.67.641	435/50 R 19.5	160 J	TL	STL1	x	x	4500 / 80
599.67.643	435/50 R 19.5	160 J	TL	STL1	x	x	4500 / 80
599.67.640	435/50 R 19.5	160 J	TL	STL1	x	x	4500 / 100
599.67.887	385/55 R 22.5	160 K (158 L)	TL	STL1	x	x	4500 / 100
599.67.891	385/65 R 22.5	160 K (158 L)	TL	STL1	x	x	4500 / 80
599.67.889	385/65 R 22.5	160 K (158 L)	TL	STL1	x	x	4500 / 100
599.67.892	385/65 R 22.5	160 K (158 L)	TL	STL1	x	x	4500 / 100
599.67.888	385/65 R 22.5	160 K (158 L)	TL	STL1	x	x	4500 / 110
599.67.890	385/65 R 22.5	160 K (158 L)	TL	STL1	x	x	4500 / 110
599.67.893	385/65 R 22.5	164 K (158 L)	TL	STL1	x	x	5000 / 100
599.67.920	425/65 R 22.5	165 K	TL	S825	x		4500 / 80
599.67.919	425/65 R 22.5	165 K	TL	S825	x		5150 / 100

Diverse

Artikel-Nr.	Größe	Last-/ Speed-Index	TT/TL	Fabrikat - Profil	M+S	3-PMSF	Tragfähigkeit kpl. Rad kg / km/h
599.67.535	205/65 R 17.5	129 / 127 K (132 / 132 G)	TL	Goodyear - KMAXT	x	x	1850 / 110
599.67.520	205/65 R 17.5	129 / 127 J (132 / 132 F)	TL	Pirelli - ST 01	x		1850 / 100
599.67.523	205/65 R 17.5	129 / 127 J (132 / 132 F)	TL	Pirelli - ST 01	x		1850 / 100
599.67.519	205/65 R 17.5	129 / 127 J (132 / 132 F)	TL	Pirelli - ST 01	x		1850 / 100
599.67.529	205/65 R 17.5	129 / 127 J (132 / 132 F)	TL	Pirelli - ST 01	x		1850 / 100



Felge											
Größe	Anschluss	ET	Bolzenloch- ausführung	Zentrie- rung	HMA	Ventil- position	Farbe	Rollwider- stand	Nass- haftung	Rollgeräusch dB	Level
6.75 x 17.5	6/161/205	0	B2	BMZ		ALV	silber	D	B	73	B
6.75 x 17.5	6/161/205	+126	B2	BZ	138	ILV	silber	D	B	73	B
6.75 x 17.5	10/176/225	+130	B33	BMZ	143	ILV	silber	D	B	73	B
6.75 x 17.5	6/161/205	+126	B2	BZ	138	ILV	silber	D	B	73	B
6.75 x 17.5	6/161/205	0	A2	BZ		ALV	silber	D	B	73	B
7.50 x 19.5	6/161/205	0	A2	BZ		ALV	silber	D	C	73	B
8.25 x 19.5	8/221/275	0	A2	BZ		ALV	silber	D	C	73	B
8.25 x 19.5	8/221/275	0	A2	BZ		ALV	silber	D	C	75	B
8.25 x 19.5	6/161/205	0	A2	BZ		ALV	silber	D	C	72	B
8.25 x 19.5	8/221/275	0	A33	BMZ		ALV	silber	D	C	72	B
14.00 x 19.5	6/161/205	0	B2	BZ		ALV	silber	B	C	72	B
14.00 x 19.5	8/221/275	0	A2	BZ		ALV	silber	B	C	72	B
14.00 x 19.5	10/281/335	0	A3	BZ		ALV	silber	B	C	72	B
14.00 x 19.5	10/281/335	0	A3	BZ		ALV	silber	B	C	72	B
11.75 x 22.5	10/281/335	0	B33	BMZ		ALV	silber	B	B	72	B
11.75 x 22.5	8/221/275	0	A2	BZ		ALV	silber	B	B	71	A
11.75 x 22.5	10/281/335	0	A3	BZ		ALV	silber	B	B	71	A
11.75 x 22.5	10/281/335	0	B33	BMZ		ALV	silber	B	B	71	A
11.75 x 22.5	10/281/335	0	B33	BMZ		ALV	silber	B	B	71	A
11.75 x 22.5	10/281/335	+120	Ø 26, M22	MZ		ALV	silber	B	B	71	A
11.75 x 22.5	10/281/335	0	B33	BMZ		ALV	silber	B	B	71	A
14.00 x 22.5	10/281/335	0	A3	BZ		ALV	silber	D	C	72	B
14.00 x 22.5	10/281/335	0	B33	BMZ		ALV	silber	D	C	72	B

BZ: bolzenzentriert · BMZ: bolzenmittenzentriert · MZ: mittenzentriert · ALV: außenliegendes Ventil · ILV: innenliegendes Ventil

Felge											
Größe	Anschluss	ET	Bolzenloch- ausführung	Zentrie- rung	HMA	Ventil- position	Farbe	Rollwider- stand	Nass- haftung	Rollgeräusch dB	Level
6.00 x 17.5	6/161/205	+70	A2	BZ		ILV	silber	C	B	70	A
6.00 x 17.5	6/161/205	0	A2	BZ		ALV	silber	D	B	68	A
6.00 x 17.5	6/161/205	+70	A2	BZ		ILV	silber	D	B	68	A
6.75 x 17.5	6/161/205	+126	B2	BZ	138	ILV	silber	D	B	68	A
6.75 x 17.5	10/176/225	+133	B33	BMZ	145	ILV	silber	D	B	68	A



LKW Räder mit Aluminium-Felge

nokian
TYRES



TL/
TT



M+S



Artikel-Nr.	Größe	Last-/ Speed-Index	TT/TL	Profil	M+S	3-PMSF	Tragfähigkeit kpl. Rad kg / km/h
599.19.105	385/65 R 22.5	160 K (158 L)	TL	E-Truck Trailer	x	x	4500 / 110
599.19.106	385/65 R 22.5	160 K (158 L)	TL	E-Truck Trailer	x	x	4500 / 110
599.19.103	385/65 R 22.5	160 K (158 L)	TL	E-Truck Trailer	x	x	4500 / 110
599.19.104	385/65 R 22.5	160 K (158 L)	TL	E-Truck Trailer	x	x	4500 / 110
599.19.109	385/65 R 22.5	160 K (158 L)	TL	E-Truck Trailer	x	x	4500 / 110
599.19.110	385/65 R 22.5	160 K (158 L)	TL	E-Truck Trailer	x	x	4500 / 110
599.19.107	385/65 R 22.5	160 K (158 L)	TL	E-Truck Trailer	x	x	4500 / 110
599.19.108	385/65 R 22.5	160 K (158 L)	TL	E-Truck Trailer	x	x	4500 / 110



ALUMINIUMFELGEN



Felge

Größe	Anschluss	ET	Bolzenloch- ausführung	Zentrie- rung	Ventil- position	Farbe	Rollwider- stand	Nass- haftung	Rollgeräusch dB	Level
11.75 x 22.5	10/281/335	0	Ø 26, M20/M22	MZ	ALV	poliert	C	B	70	A
11.75 x 22.5	10/281/335	0	Ø 26, M20/M22	MZ	ALV	poliert + Accu-Shield	C	B	70	A
11.75 x 22.5	10/281/335	+120	Ø 26, M20/M22	MZ	ALV	poliert	C	B	70	A
11.75 x 22.5	10/281/335	+120	Ø 26, M20/M22	MZ	ALV	poliert + Accu-Shield	C	B	70	A
11.75 x 22.5	10/281/335	0	Ø 32, M20/M22	MZ	ALV	poliert	C	B	70	A
11.75 x 22.5	10/281/335	0	Ø 32, M20/M22	MZ	ALV	poliert + Accu-Shield	C	B	70	A
11.75 x 22.5	10/281/335	+120	Ø 32, M20/M22	MZ	ALV	poliert	C	B	70	A
11.75 x 22.5	10/281/335	+120	Ø 32, M20/M22	MZ	ALV	poliert + Accu-Shield	C	B	70	A

MZ: mittenzentriert · ALV: außenliegendes Ventil





PKW - Trailer Räder mit Stahl-Felge

PKW - Trailer Räder mit Stahl-Felge

Artikel-Nr.	Größe	Last-/ Speed-Index	TL/ TT	Fabrikat	Profil	Tragfähigkeit kpl. Rad kg / km/h
596.96.004	4.80/4.00 - 8	70 M	TT	Kenda	K371	335 / 130
596.96.008	5.70/5.00 - 8	77 M	TL	Deli	S-378	300 / 100
596.96.012	5.00 - 10	79 M	TL	Kenda	K364	437 / 130
596.00.090	145/80 R 13	78 N	TL	Boka Trailer Line	FT 01	425 / 140
599.96.072	155/70 R 13	79 N	TL	Boka Trailer Line	FT 01	437 / 140
599.96.049	155/80 R 13	84 N	TL	Boka Trailer Line	FT 01	500 / 140
599.96.037	175/70 R 13	86 N	TL	BK Trailer	202	530 / 140
599.96.036	175/70 R 13	86 N	TL	BK Trailer	202	530 / 140
596.00.133	185/70 R 13	93 N	TL	BK Trailer	202	600 / 140
596.00.134	185/70 R 13	93 N	TL	BK Trailer	202	625 / 140
596.38.027	185/65 R 14	93 N	TL	Boka Trailer Line	FT 01	650 / 140
597.58.072	195/70 R 14	96 N	TL	Boka Trailer Line	FT 01	710 / 140
597.73.270	195/65 R 15	93 N	TL	BK Trailer	202	650 / 140

PKW - Trailer Räder mit Stahl-Felge (C-Decken)

Artikel-Nr.	Größe	Last-/ Speed-Index	TL/ TT	Fabrikat	Profil	Tragfähigkeit kpl. Rad kg / km/h
597.19.829	155/70 R 12 C	104 / 102 N	TL	BK Trailer	204	900 / 140
599.95.223	185/60 R 12 C	104 / 102 N	TL	BK Trailer	204	900 / 140
596.00.040	195/60 R 12 C	104 / 102 N	TL	GT Radial	KargoMax ST 6000	900 / 140
596.96.532	225/55 R 12 C	112 N	TL	Kenda	KR33A	950 / 140
596.96.534	225/55 R 12 C	112 N	TL	Kenda	KR33A	900 / 140
596.96.106	155 R 13 C	91 / 89 N	TL	GT Radial	KargoMax ST 6000	600 / 140
596.96.092	155 R 13 C	91 / 89 N	TL	GT Radial	KargoMax ST 6000	615 / 140
596.00.105	165 R 13 C	96 / 94 N	TL	BK Trailer	203	670 / 140
596.00.109	165 R 13 C	96 / 94 N	TL	BK Trailer	203	625 / 140
596.00.138	185/70 R 13 C	106 / 104 N	TL	GT Radial	Savero	950 / 140
597.37.469	195/50 R 13 C	104 / 102 N	TL	Boka Trailer Line	FT 02	900 / 140



Felge

Größe	Anschluss	ET	Bolzenloch- ausführung	Zentrie- rung	Ventil- position	Farbe	Rollwider- stand	Nass- haftung	Rollgeräusch dB	Level
2.50 x 8	4/60/100	0	D12, Ø16 mm, R12 (Kugel)	BZ	ALV	silber				
3.00 x 8	4/60/100	0	D12, Ø16 mm, R12 (Kugel)	BZ	ALV	silber				
3.50 x 10	4/60/100	0	Ø14.5 mm, C60 (Kegel)	BZ	ALV	silber				
4 x 13	4/57/100	+30	E16, Ø15.5 mm, C60 (Kegel)	BZ	ALV	silber	D	C	70	B
4 x 13	4/57/100	+30	E16, Ø15.5 mm, C60 (Kegel)	BZ	ALV	silber	D	C	71	B
4 x 13	4/57/100	+30	E16, Ø15.5 mm, C60 (Kegel)	BZ	ALV	silber	D	C	71	B
4.5 x 13	4/57/100	+30	E16, Ø15.5 mm, C60 (Kegel)	BZ	ALV	silber	D	D	72	B
4.5 x 13	5/67/112	+30	E12, Ø16 mm, R12 (Kugel)	BZ	ALV	silber	D	D	72	B
4.5 x 13	4/57/100	+30	E16, Ø15.5 mm, C60 (Kegel)	BZ	ALV	silber	D	D	72	B
4.5 x 13	5/67/112	+30	E12, Ø16 mm, R12 (Kugel)	BZ	ALV	silber	D	D	72	B
5.5 x 14	5/67/112	+30	E12, Ø16 mm, R12 (Kugel)	BZ	ALV	silber	D	C	71	B
5.5 x 14	5/67/112	+30	E12, Ø16 mm, R12 (Kugel)	BZ	ALV	silber	D	C	72	B
5.5 x 15	5/66/112	+30	Ø17 mm, R12 (Kugel)	BZ	ALV	silber	D	D	72	B



Felge

Größe	Anschluss	ET	Bolzenloch- ausführung	Zentrie- rung	Ventil- position	Farbe	Rollwider- stand	Nass- haftung	Rollgeräusch dB	Level
4.5 x 12	5/67/112	+20	E12, Ø16 mm, R12 (Kugel)	BZ	ALV	silber	D	D	71	B
5.5 x 12	5/67/112	+30	E12, Ø16 mm, R12 (Kugel)	BZ	ALV	silber	D	D	72	B
5.5 x 12	5/67/112	+30	E12, Ø16 mm, R12 (Kugel)	BZ	ALV	silber	C	C	70	B
7.00 x 12	5/67/112	-4	E12, Ø16 mm, R12 (Kugel)	BZ	ALV	silber	D	C	71	B
7.00 x 12	5/67/112	+10	E12, Ø16 mm, R12 (Kugel)	BZ	ALV	silber	D	C	71	B
4.5 x 13	4/57/100	+30	E16, Ø15.5 mm, C60 (Kegel)	BZ	ALV	silber	C	C	70	B
4.5 x 13	5/67/112	+30	E12, Ø16 mm, R12 (Kugel)	BZ	ALV	silber	C	C	70	B
4.5 x 13	4/57/100	+30	E16, Ø15.5 mm, C60 (Kegel)	BZ	ALV	silber	D	D	72	B
4.5 x 13	5/67/112	+30	E12, Ø16 mm, R12 (Kugel)	BZ	ALV	silber	D	D	72	B
6 x 13	5/67/112	+30	E12, Ø16 mm, R12 (Kugel)	BZ	ALV	silber	C	B	73	B
6 x 13	5/66.6/112	+30	E12, Ø16 mm, R12 (Kugel)	BZ	ALV	silber	C	B	72	B

BZ: bolzenzentriert · ALV: außenliegendes Ventil



PKW - Trailer Räder mit Stahl-Felge

PKW - Trailer Räder mit Stahl-Felge (C-Decken)

Artikel-Nr.	Größe	Last-/ Speed-Index	TT/TL	Fabrikat	Profil	Tragfähigkeit kpl. Rad kg / km/h
596.00.360	185 R 14 C	104 / 102 N	TL	Boka Trailer Line	FT 02	900 / 140
596.00.518	195 R 14 C	108 / 106 N	TL	BK Trailer	203	950 / 140
596.00.702	205 R 14 C	109 / 107 N	TL	BK Trailer	203	950 / 140
596.00.701	205 R 14 C	109 / 107 N	TL	BK Trailer	203	1030 / 140
596.00.969	225/70 R 15 C	116 / 114 N	TL	BK Trailer	203	1250 / 140

PKW - Trailer Räder mit Stahl-Felge (3PMSF)

Artikel-Nr.	Größe	Last-/ Speed-Index	TT/TL	Fabrikat	Profil	Tragfähigkeit kpl. Rad kg / km/h
597.19.832	155/70 R 12 C	104 / 101 N	TL	Kenda	KR500 Winter Trailer	900 / 140
599.95.224	185/60 R 12 C	104 / 101 N	TL	Kenda	KR500 Winter Trailer	900 / 140
596.00.645	225/75 R 16 C	121 / 120 R	TL	Onyx	NY-AS 687	1250 / 140

Vormontierte PKW - Trailer Räder mit Stahl-Felge

Artikel-Nr.	Größe	Last-/ Speed-Index	TT/TL	Fabrikat	Profil	Tragfähigkeit kpl. Rad kg / km/h
596.00.090	145/80 R 13	78 N	TL	Boka Trailer Line	FT 01	425 / 140
599.96.072	155/70 R 13	79 N	TL	Boka Trailer Line	FT 01	437 / 140
599.96.049	155/80 R 13	84 N	TL	Boka Trailer Line	FT 01	500 / 140
597.37.469	195/50 R 13 C	104 / 102 N	TL	Boka Trailer Line	FT 02	900 / 140
596.38.027	185/65 R 14	93 N	TL	Boka Trailer Line	FT 01	650 / 140
596.00.360	185 R 14 C	104 / 102 N	TL	Boka Trailer Line	FT 02	900 / 140
597.58.072	195/70 R 14	96 N	TL	Boka Trailer Line	FT 01	710 / 140



Felge

Größe	Anschluss	ET	Bolzenloch- ausführung	Zentrie- rung	Ventil- position	Farbe	Rollwider- stand	Nass- haftung	Rollgeräusch dB	Level
5.5 x 14	5/67/112	+30	E12, Ø16 mm, R12 (Kugel)	BZ	ALV	silber	C	B	71	B
5.5 x 14	5/67/112	+30	E12, Ø16 mm, R12 (Kugel)	BZ	ALV	silber	D	D	72	B
5.5 x 14	5/67/112	+30	E12, Ø16 mm, R12 (Kugel)	BZ	ALV	silber	D	D	72	B
6 x 14	6/161/205	-5	E2, Ø21.5 mm, R16 (Kugel)	BZ	ALV	silber	D	D	72	B
6 x 15	6/161/205	0	A2, Ø21.5 mm, R16 (Kugel)	BZ	ALV	silber	D	D	72	B



Felge

Größe	Anschluss	ET	Bolzenloch- ausführung	Zentrie- rung	Ventil- position	Farbe	Rollwider- stand	Nass- haftung	Rollgeräusch dB	Level
4.5 x 12	5/67/112	+20	E12, Ø16 mm, R12 (Kugel)	BZ	ALV	silber	E	B	72	B
5.5 x 12	5/67/112	+30	E12, Ø16 mm, R12 (Kugel)	BZ	ALV	silber	E	B	72	B
6 x 16	6/161/205	-5	A2, Ø21.5 mm, R16 (Kugel)	BZ	ALV	silber	D	D	73	B



Felge

Größe	Anschluss	ET	Bolzenloch- ausführung	Zentrie- rung	Ventil- position	Farbe	Rollwider- stand	Nass- haftung	Rollgeräusch dB	Level
4 x 13	4/57/100	+30	E16, Ø15.5 mm, C60 (Kegel)	BZ	ALV	silber	D	C	70	B
4 x 13	4/57/100	+30	E16, Ø15.5 mm, C60 (Kegel)	BZ	ALV	silber	D	C	71	B
4 x 13	4/57/100	+30	E16, Ø15.5 mm, C60 (Kegel)	BZ	ALV	silber	D	C	71	B
6 x 13	5/66.6/112	+30	E12, Ø16 mm, R12 (Kugel)	BZ	ALV	silber	C	B	72	B
5.5 x 14	5/67/112	+30	E12, Ø16 mm, R12 (Kugel)	BZ	ALV	silber	D	C	71	B
5.5 x 14	5/67/112	+30	E12, Ø16 mm, R12 (Kugel)	BZ	ALV	silber	C	B	71	B
5.5 x 14	5/67/112	+30	E12, Ø16 mm, R12 (Kugel)	BZ	ALV	silber	D	C	72	B

BZ: bolzenzentriert · ALV: außenliegendes Ventil



PKW - Trailer Räder mit Aluminium-Felge

PKW - Trailer Räder mit Aluminium-Felge

Artikel-Nr.	Größe	Last-/ Speed-Index	TL/ TT	Fabrikat	Profil	Tragfähigkeit kpl. Rad kg / km/h
596.00.137	185/70 R 13	93 N	TL	BK Trailer	202	650 / 140
596.38.031	185/65 R 14	93 N	TL	Boka Trailer Line	FT 01	650 / 140
597.58.078	195/70 R 14	96 N	TL	Boka Trailer Line	FT 01	710 / 140
597.73.271	195/65 R 15	93 N	TL	BK Trailer	202	650 / 140

PKW - Trailer Räder mit Aluminium-Felge (C-Decken)

Artikel-Nr.	Größe	Last-/ Speed-Index	TL/ TT	Fabrikat	Profil	Tragfähigkeit kpl. Rad kg / km/h
599.67.243	195/55 R 10 C	98 / 96 N	TL	BK Trailer	204	750 / 140
597.37.476	195/50 R 13 C	104 / 102 N	TL	Boka Trailer Line	FT 02	900 / 140
596.00.361	185 R 14 C	104 / 102 N	TL	Boka Trailer Line	FT 02	900 / 140
596.00.521	195 R 14 C	108 / 106 N	TL	BK Trailer	203	950 / 140
596.00.708	205 R 14 C	109 / 107 N	TL	BK Trailer	203	950 / 140
596.00.975	225/70 R 15 C	116 / 114 N	TL	BK Trailer	203	900 / 140

PKW - Trailer Räder mit Aluminium-Felge (3PMSF)

Artikel-Nr.	Größe	Last-/ Speed-Index	TL/ TT	Fabrikat	Profil	Tragfähigkeit kpl. Rad kg / km/h
597.37.477	195/50 R 13 C	104 / 101 N	TL	Kenda	KR500 Winter Trailer	900 / 140
596.00.964	195/70 R 15 C	104 / 102 R	TL	Onyx	NY-AS 687	900 / 140
596.00.979	225/70 R 15 C	112 / 110 R	TL	Onyx	NY-W287	900 / 140



Felge

Größe	Anschluss	ET	Bolzenloch- ausführung	Zentrie- rung	Ventil- position	Farbe	Rollwider- stand	Nass- haftung	Rollgeräusch dB	Level
6 x 13	5/67/112	+30	Ø16 mm, R12 (Kugel)	BZ	ALV	silber	D	D	72	B
5.5 x 14	5/66.6/112	+30	Ø15 mm, C60 (Kegel)	BZ	ALV	silber	D	C	71	B
5.5 x 14	5/66.6/112	+30	Ø15 mm, C60 (Kegel)	BZ	ALV	silber	D	C	72	B
6 x 15	5/67/112	+30	Ø15 mm, C60 (Kegel)	BZ	ALV	silber	D	D	72	B



Felge

Größe	Anschluss	ET	Bolzenloch- ausführung	Zentrie- rung	Ventil- position	Farbe	Rollwider- stand	Nass- haftung	Rollgeräusch dB	Level
6 x 10	5/67/112	-4	Ø16 mm, R12 (Kugel)	BZ	ALV	silber				
6 x 13	5/67/112	+30	Ø16 mm, R12 (Kugel)	BZ	ALV	silber	C	B	72	B
5.5 x 14	5/66.6/112	+30	Ø15 mm, C60 (Kegel)	BZ	ALV	silber	C	B	71	B
5.5 x 14	5/66.6/112	+30	Ø15 mm, C60 (Kegel)	BZ	ALV	silber	D	D	72	B
5.5 x 14	5/66.6/112	+30	Ø15 mm, C60 (Kegel)	BZ	ALV	silber	D	D	72	B
6 x 15	5/67/112	+30	Ø15 mm, C60 (Kegel)	BZ	ALV	silber	D	D	72	B



Felge

Größe	Anschluss	ET	Bolzenloch- ausführung	Zentrie- rung	Ventil- position	Farbe	Rollwider- stand	Nass- haftung	Rollgeräusch dB	Level
6 x 13	5/67/112	+30	Ø16 mm, R12 (Kugel)	BZ	ALV	silber	E	B	72	B
6 x 15	5/67/112	+30	Ø15 mm, C60 (Kegel)	BZ	ALV	silber	D	D	73	B
6 x 15	5/67/112	+30	Ø15 mm, C60 (Kegel)	BZ	ALV	silber	D	D	73	B

BZ: bolzenzentriert · ALV: außenliegendes Ventil

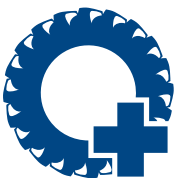

ZUBEHÖR

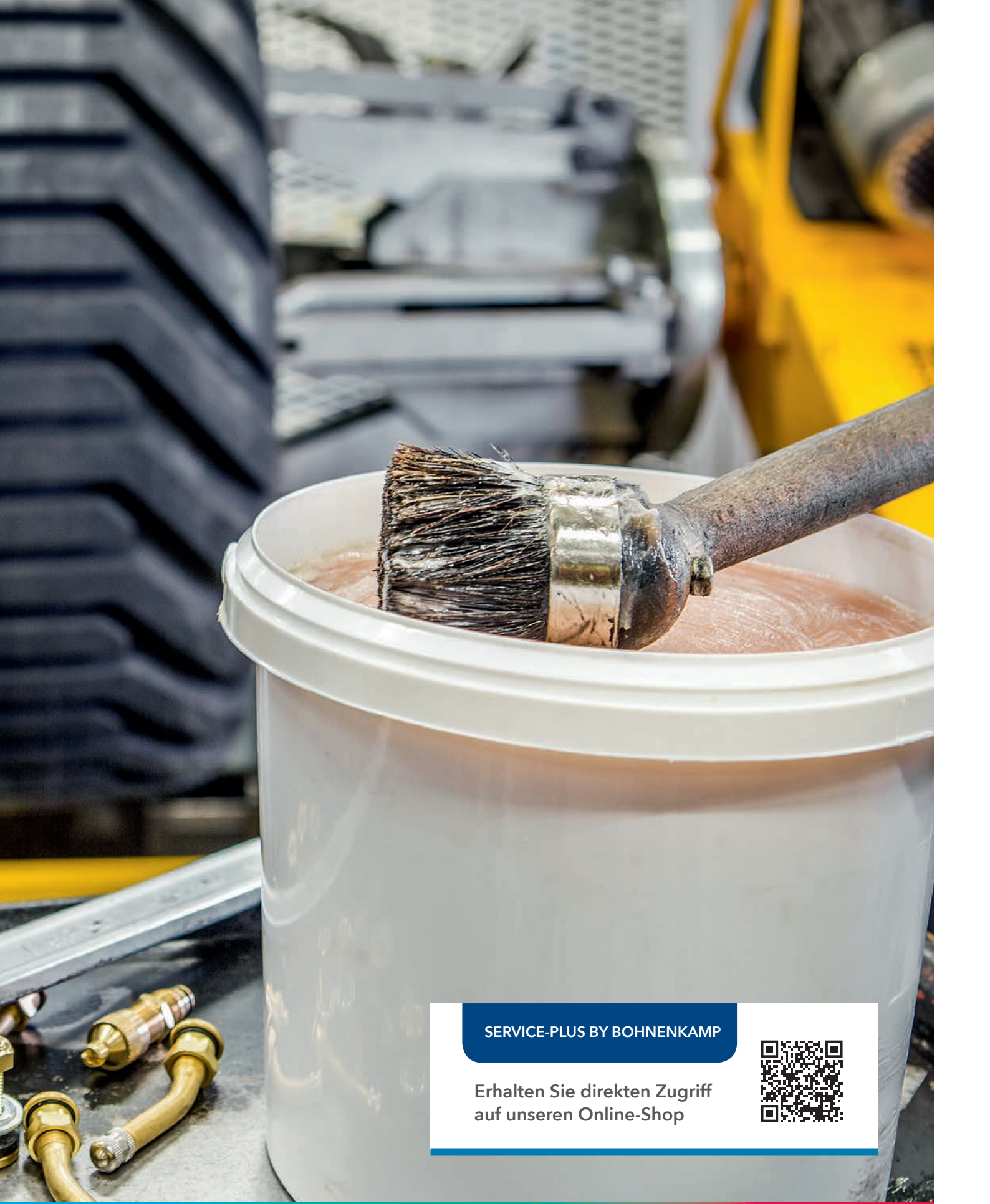

SERVICE-PLUS BY BOHNENKAMP

Erhalten Sie direkten Zugriff
auf unseren Online-Shop





LKW Standard

Artikel-Nr.	Ventilausführung	Ventilbezeichnung	Ventilbezeichnung ETRTO	Ventillochdurchmesser [mm]	Länge [mm]	max. Luftdruck [bar]	Winkel [°]	Abbildung
472.01.035	Metallventil	32 MS / TR 575	V3-21-1	15.7	33.0	14.0	gerade	V1
472.01.100	Metallventil	40 MSF	V3-12-1	15.7	40.0	14.0	90	V2
472.01.040	Metallventil	41 MS	V3-20-1	9.7	41.0	14.0	gerade	V3
472.01.034	Metallventil	TR 570 G 17	n.v.	15.7	54.0	13.8	36	V10
472.01.045	Metallventil	58 MS	V3-22-1	9.7	58.0	14.0	45	V4
472.01.110	Metallventil	65 MSF	V3-16-1	20.5	62.0	14.0	150	V5
472.01.050	Metallventil	70 MS	V3-20-5	9.7	70.0	14.0	27	V6
472.01.052	Metallventil	75 MSF	V3-14-1	15.7	71.0	14.0	90 mit 1 Sprung	V7
472.01.060	Metallventil	90 MS	V3-20-4	9.7	90.0	14.0	27	V8
472.01.063	Metallventil	120 MSF	V3-18-4	20.5	110.0	14.0	90 mit 1 Sprung	V9

LKW Aluminium - Felgen

Artikel-Nr.	Ventilausführung	Ventilbezeichnung	Ventilbezeichnung ETRTO	Ventillochdurchmesser [mm]	Länge [mm]	max. Luftdruck [bar]	Winkel [°]	Abbildung
404.81.909	Metallventil	TR 542	n.v.	9.7	32.0	14.0	gerade	V25
404.81.905	Metallventil	40 MS	n.v.	9.7	40.0	14.0	gerade	V14
404.81.906	Metallventil	54 MS	n.v.	9.7	54.0	14.0	gerade	V15
404.81.904	Metallventil	60 MS	n.v.	9.7	60.0	14.0	gerade	V12
404.81.903	Metallventil	TR 543 D	n.v.	9.7	66.0	14.0	60	V13
404.81.900	Metallventil	70-7 MS	n.v.	9.7	70.0	14.0	7	V11
404.81.901	Metallventil	70-27 MS	n.v.	9.7	70.0	14.0	27	V16
404.81.908	Metallventil	74-27 MS	n.v.	9.7	70.0	14.0	27	V26
404.81.902	Metallventil	60-45 MS	n.v.	9.7	70.0	14.0	45	V13
404.81.907	Metallventil	83 MS	n.v.	9.7	83.0	14.0	gerade	V17

PKW - Trailer

Artikel-Nr.	Ventilausführung	Ventilbezeichnung	Ventilbezeichnung ETRTO	Ventillochdurchmesser [mm]	Länge [mm]	max. Luftdruck [bar]	Winkel [°]	Abbildung
472.00.660	Gummiventil	TR 412	V2-03-6	11.3	33.0	4.5	gerade	V18
472.00.650	Gummiventil	TR 413	V2-03-1	11.3	43.0	4.5	gerade	V19
472.00.570	Gummiventil	TR 415	V2-03-3	15.7	43.0	4.5	gerade	V21
472.00.560	Gummiventil	TR 414	V2-03-2	11.3	49.0	4.5	gerade	V20
472.00.580	Gummiventil	TR 418	V2-03-4	11.3	61.5	4.5	gerade	V22
472.01.095	Metallventil	42 MS	n.v.	11.3	42.0	20.0	gerade	V23
472.00.670	Hochdruck-Gummiventil	TR 600 XHP	n.v.	11.3	45.5	6.9	gerade	V24



Ventil 32 MS

Ventil 40 MSF - 16

Ventil 41 MS

Ventil 58 MS

Ventil 65MSF

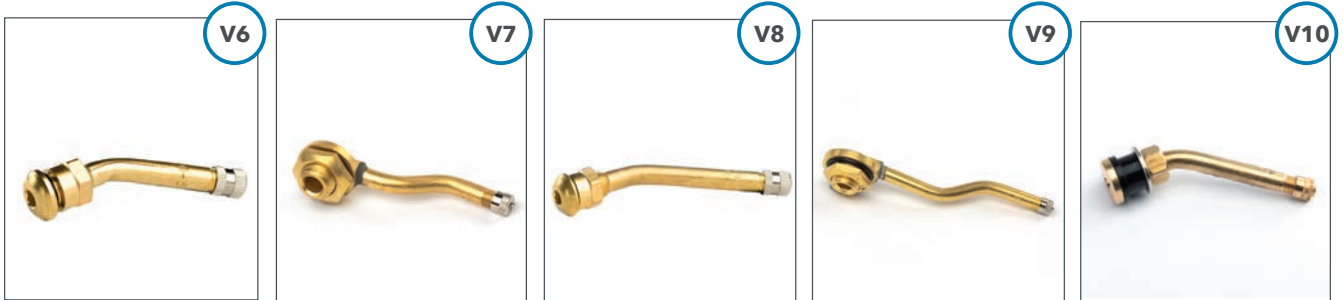

Ventil 70 MS

Ventil 75 MSF

Ventil 90 MS

Ventil 120 MS

Ventil TR 570 G17



Ventil 70-7 MS

Ventil 70-27 MSF

Ventil 60-45 MS/
TR 543 D

Ventil 40 MS

Ventil 54 MS



Ventil 60 MS

Ventil 83 MS

Ventil TR 412

Ventil TR 413

Ventil TR 414

Ventil TR 415



Ventil TR 418

Ventil T42 MS

Ventil TR 600 XHP

Ventil TR 542

Ventil 74 MS-27



Ventil Zubehör

Artikel-Nr.	Beschreibung	Zusatzinfo	Verpackungseinheit Stück	Abbildung
472.00.870	Ventilkappe schwarz	Kunststoff	100	V27
404.81.921	LKW-Ventilverlängerung	gerade, 71 mm lang		V28
404.81.922	LKW-Ventilverlängerung	gerade, 150 mm lang		V28
404.81.931	LKW-Ventilverlängerungskappe	gerade, 22 mm lang		V29

Radbefestigungen LKW

Artikel-Nr.	Beschreibung	Beschreibung 2	Beschreibung 3	Abbildung
404.81.943	Radmutter - M18 X 1.5, kurze Führung	SW 27 mm, Ø25/42 mm, Höhe 25/35 mm	geometrisiert, für Alufelgen	V30
404.81.944	Radmutter - M18 X 1.5, lange Führung	SW 27 mm, Ø25/42 mm, Höhe 25/52 mm	geometrisiert, für Alufelgen	V31
404.81.945	Radmutter - M20 X 1.5, kurze Führung	SW 30 mm, Ø28.5/52 mm, Höhe 30/39 mm	geometrisiert, für Alufelgen	V30
404.81.946	Radmutter - M20 X 1.5, lange Führung	SW 30 mm, Ø28.5/52 mm, Höhe 27/62 mm	geometrisiert, für Alufelgen	V31
404.81.315	Radmutter - M22 x 1.5, ohne Führung	SW 32 mm, Ø46 mm, Höhe 26 mm	geometrisiert, für Stahl-/Alufelgen	V32
404.81.330	Radmutter - M22 x 1.5, kurze Führung	SW 32 mm, Ø30.5/53 mm, Höhe 27/34 mm	geometrisiert, für Alufelgen	V30
404.81.942	Radmutter - M22 X 1.5, lange Führung	SW 32 mm, Ø30.5/50 mm, Höhe 26/46 mm	geometrisiert, für Alufelgen	V31
404.81.335	Radmutter - M22 x 1.5, lange Führung	SW 32 mm, Ø30.5/53 mm, Höhe 27/62 mm	geometrisiert, für Alufelgen	V31
404.81.949	Radmutter - Scania, 7/8" 11BSF, kurze Führung	SW 32 mm, Ø30.5/53 mm, Höhe 27/39 mm	geometrisiert, für Alufelgen	V30
404.81.950	Radmutter - Scania, 7/8" 11BSF, lange Führung	SW 32 mm, Ø30.5/53 mm, Höhe 27/62 mm	geometrisiert, für Alufelgen	V31
404.81.951	Radmutter - Volvo, 7/8" 14UNF, kurze Führung	SW 32 mm, Ø30.5/53 mm, Höhe 27/39 mm	geometrisiert, für Alufelgen	V30
404.81.952	Radmutter - Volvo, 7/8" 14UNF, lange Führung	SW 32 mm, Ø30.5/53 mm, Höhe 27/62 mm	geometrisiert, für Alufelgen	V31
404.81.340	Radmutterkappe - Kunststoff verchromt	SW 32 mm, Ø55 mm, Höhe 38 mm		V33
404.81.932	Radmutterkappe - Kunststoff verchromt	SW 32 mm, Ø58 mm, Höhe 45 mm		V33
404.81.933	Radmutterkappe - Edelstahl	SW 32 mm, Ø55 mm, Höhe 45 mm		V34
404.81.934	Abzieher für Radmutterkappe LKW			
404.81.935	LKW-Inlay Kunststoff für Radmuttern			

Radmutterindikatoren

Artikel-Nr.	Beschreibung	Ausführung	Abbildung
404.81.348	Radmutterindikator für Schlüsselweite 27mm	Kunststoff, gelb	V35
404.81.349	Radmutterindikator für Schlüsselweite 30mm	Kunststoff, gelb	V35
404.81.350	Radmutterindikator für Schlüsselweite 32mm	Kunststoff, gelb	V35

PKW - Trailer

Artikel-Nr.	Beschreibung	Auführung	Abbildung
398.99.315	Radschraube für Stahlfelgen	Kugelbund, M12 x 1.5 x 25 mm	V37
398.99.415	Radschraube für Stahlfelgen	Kegelbund, M12 x 1.5 x 24 mm	V36
398.99.310	Radschraube für Alufelgen	Kugelbund, M12 x 1.5 x 28 mm	V37
398.99.400	Radschraube für Alufelgen	Kegelbund, M12 x 1.5 x 28 mm	V36

Zubehör für PKW - Trailer

Artikel-Nr.	Beschreibung	Beschreibung 2	Design	Abbildung
398.99.408	Nabenkappe 60 mm	für Alufelge TR1, TR12	poliert	V41
398.99.402	Nabenkappe 60 mm	für Alufelge TR3, TR8	silber	V39
398.99.407	Nabenkappe 60 mm	für Alufelge BK01, BK8	Flamme	V40
398.99.574	Nabenkappe 60 mm	für Alufelge BK01, BK8	Car Fashion	V40
398.99.001	Nabenkappe 65 mm	für Alufelge BK510, BK513, BK514	BK TRAILER	V38
398.99.002	Nabenkappe 65 mm	für Alufelge BK510, BK513, BK514	BOKA TRAILER LINE	V38



V27

Ventilkappe schwarz



V28

Ventilverlängerung



V29

Ventilverlängerungs-
kappe



V30

Radmutter
kurze Führung



V31

Radmutter
lange Führung



V32

Radmutter



V33

Radmutterkappe
Kunststoff verchromt



V34

Radmutterkappe
Edelstahl



V35

Radmutterindikator



V36

Radschraube



V37

Radschraube



V38

Nabenkappe
für Alufelgen BK 510,
BK 513 und BK 514



V39

Nabenkappe
für Alufelgen TR 3
und TR 8



V40

Nabenkappe
für Alufelgen Brock B8
und TM 604



V41

Nabenkappe
für Alufelgen TR1, TR12



Montierhebel und Werkzeug

Artikel-Nr.	Beschreibung	Abbildung
472.00.611	Montierhebel 500 mm lang für PKW, Implement und LLKW	Z1
472.00.612	Montierhebel 1100 mm lang für LKW, AS, EM und Forst	Z2
472.00.730	Ventilschrauber für Ventileinsätze mit Gewinde VG5 und VG8 (PKW, Agrar, Zweirad, LLKW und LKW)	Z3
472.00.760	Ventilzange für Snap In Ventile	Z4

Montagepaste und Schmiermittel

Artikel-Nr.	Beschreibung	Abbildung
472.00.805	Reifen-Montagepaste 5.0 Kg Eimer, BOKA SUPER MOUNT / PKW + LLKW + LKW	Z5
472.00.806	Reifen-Montagepaste 10.0 Kg Eimer, BOKA SUPER MOUNT / PKW + LLKW + LKW	Z5
47.200.811	Reifen-Montagepaste 5.0 Kg Eimer, EURO-TIRE-GREASE / LLKW + LKW - Premium	Z6
472.00.816	Spezialpinsel für Montagepaste Ø 40 mm, 400 mm lang mit Holzstiel und Chinaborsten	Z7
472.00.788	Demontagefluid, 400 ml Spraydose	Z8
472.00.786	Auswuchtgranulat 8 Kg Eimer (PKW Anhänger, LLKW und LKW)	Z9

Befüllrichtungen und Anschlüsse

Artikel-Nr.	Beschreibung	Abbildung
472.00.960	Hebelstecknippel für Ventilgewinde VG8 für 6 mm Schlauchanschluss, (PKW, Agrar, Zweirad, LLKW und LKW)	Z10
472.00.965	Momentstecknippel für Ventilgewinde VG8, für 6 mm Schlauchanschluss, (PKW, Agrar, Zweirad, LLKW und LKW)	Z11
472.00.970	Hebelstecknippel für Ventilgewinde VG8 für 8 mm Schlauchanschluss(PKW, Agrar, Zweirad, LLKW und LKW)	Z10
472.01.010	Handreifenfüllmesser 0-10 BAR mit Momentstecknippel, geeicht	Z12
499.99.020	Aufpumphilfe "BEAD BAZOOKA", 9 l Kesselinhalt, bis 10 bar (PKW, Agrar, Zweirad, LLKW und LKW bis 22.5 Zoll)	Z15
472.02.121	Aufpumphilfe "AUTO BOOSTER", 38 l Kesselinhalt, bis 8 bar(Agrar, LKW und EM ab 22.5 Zoll)	Z14
472.02.126	Pumpautomat "ACCURA D12" mit 7.5 m Schlauch und Hebelstecker, bis 10 bar	Z13



Z1

Montierhebel 500 mm lang



Z2

Montierhebel 1100 mm lang



Z3

Ventilschrauber

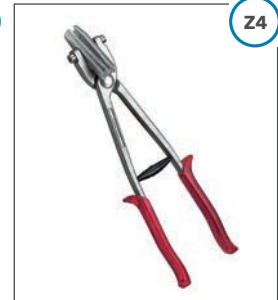

Z4

Ventilzange



Z5

Montagepaste
BOKA SUPER MOUNT



Z6

Montagepaste
EURO-TIRE-GREASE



Z7

Spezialpinsel für
Montagepaste



Z8

Demontagefluid



Z9

Auswuchtgranulat



Z10

Hebelstecknippel



Z11

Momentstecknippel



Z12

Handreifenfüllmesser



Z13

Pumpautomat



Z14

Aufpumphilfe Auto Booster



Z15

Aufpumphilfe Bead Bazooka



Technische Informationen: Grundlagen Reifen und Felgen



Bohnenkamp
■ ■ ● Moving Professionals



Grundlagen Reifen

Aufbau

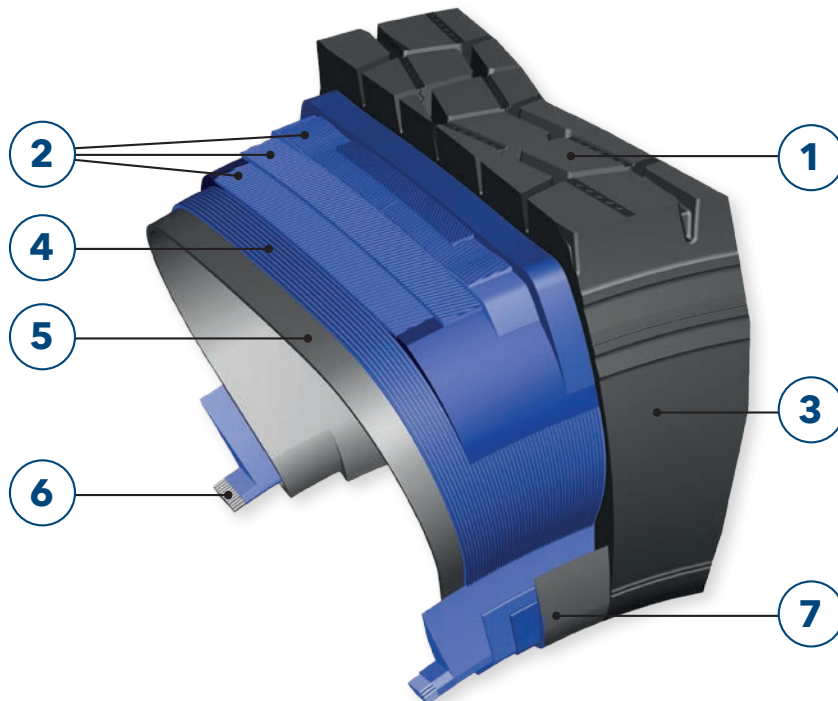

1 Lauffläche

Mit direktem Kontakt zum Untergrund ist sie für die Traktion und Lenkung zuständig. Der Anwendungsbereich und die Achsposition sind ausschlaggebend für das Profil der Lauffläche.

2 Gürtellagen

Der Stahlgürtel besteht aus mehreren Lagen. Er stabilisiert die Lauffläche und beschränkt die Ausdehnung der Karkasse während des Gebrauchs. Damit trägt er enorm zur Stabilität des Reifens bei.

3 Seitenwand

Die Seitenwand schützt die Karkasse vor äußeren Einwirkungen und Zerstörung. Außerdem sind auf ihr alle wichtigen Informationen wie beispielsweise Größe, Last und Geschwindigkeit vermerkt.

4 Karkasse

Die Karkasse ist das eigentliche Gerüst des Reifens. Der Unterbau ist aus mehreren Gewebeschichten, Kunstfasern oder Kunstseide bzw. Stahlbändern aufgebaut, die in hartem Gummi eingebettet sind.

5 Innenseele/Inliner

Diese Innenschicht ist eine abdichtende Gummischicht, die bei schlauchlosen Reifen eingesetzt wird. Sie reicht bis auf die Höhe des Felgenhorns und um die Wulst herum, sodass Luft aus dem Reifeninneren nicht entweichen und Feuchtigkeit von außen nicht eindringen kann.

6 Wulstkern

Das Innere der Reifenwulst besteht aus Stahldrähten, die den Durchmesser ergeben, aber auch für den optimalen Sitz des Reifens auf der Felge sorgen.

7 Wulst

Auch Reifenfuß genannt; sie hält den Reifen auf der Felge, indem sie sich beim Aufziehen fest gegen das Felgenhorn der Felge presst.

Abmessung und Beschriftung

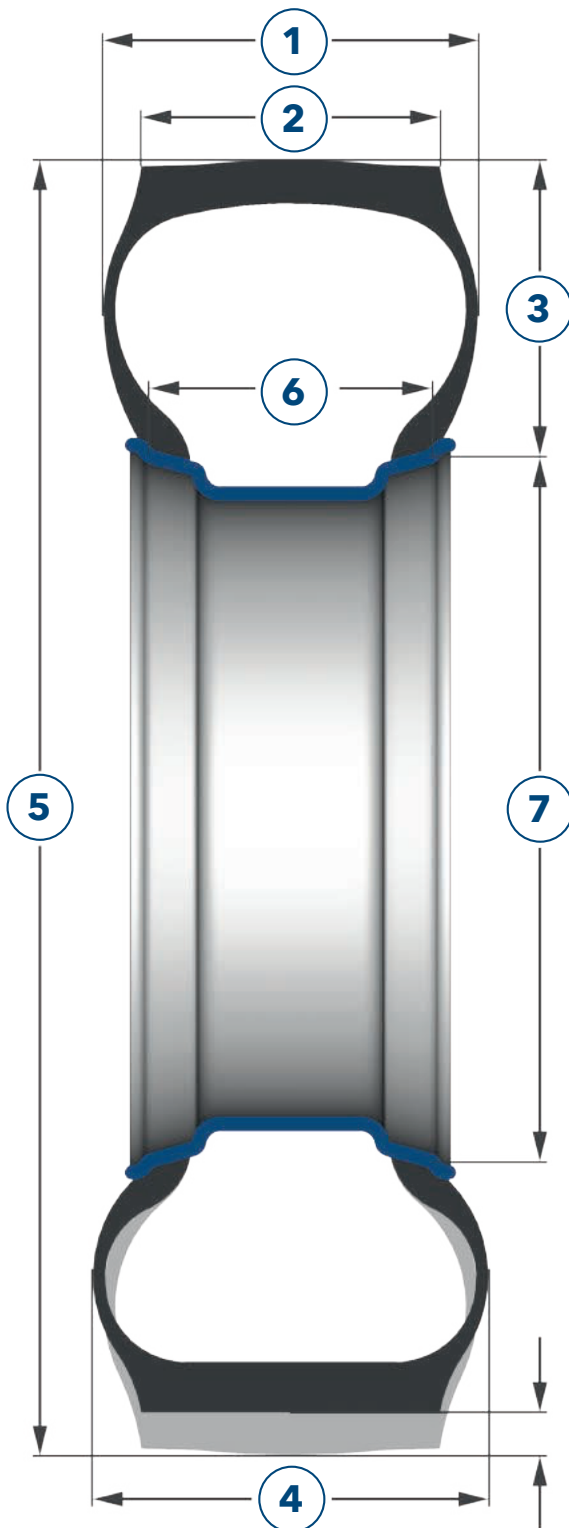
**1 Querschnittsbreite**

Die Breite des Reifens in mm, gemessen von Seitenwand zu Seitenwand eines unbelasteten, auf der empfohlenen Felge montierten und vorschriftsmäßig (Betriebsluftdruck) aufgepumpten Reifens.

2 Profilbreite

Breite des Profils in mm, gemessen von Rand zu Rand des Profils eines unbelasteten, auf der empfohlenen Felge montierten und vorschriftsmäßig (Betriebsluftdruck) aufgepumpten Reifens.

3 Reifenhöhe

Der Abstand von der Wulsthöhe zum äußeren Profilbereich

4 Querschnittsbreite

Die Breite des Querschnitts unter Last

5 Außendurchmesser

Der maximale Durchmesser in mm eines unbelasteten, auf der empfohlenen Felge montierten und vorschriftsmäßig (Betriebsluftdruck) aufgepumpten Reifens.

6 Felgenbreite

Breite der Felge, gemessen in mm von Flansch zu Flansch.

7 Felgendurchmesser

Der von Wulstsitz zu Wulstsitz gemessene Durchmesser in mm.



Grundlagen Reifen

Das neue EU Reifen-Label

Mit der Einführung des EU-Labels soll die Fahrzeugemissionen reduziert und somit ein Beitrag zur Klimaneutralität 2050 geleistet werden.

Für die bewusste Kaufentscheidung des Verbrauchers, gilt für hergestellte Reifen der Klassen C1, C2 und C3 ab dem 01. Mai 2021 ein neues Reifenlabel, welches durch die Angaben des Rollwiderstands, der Nasswerte und der Geräuscheinstuflung umfassend über die Eigenschaften des Reifens informiert. Zusätzlich können die individuellen Reifendaten über einen QR-Code aus der EU-Datenbank (EPREL) heruntergeladen werden.

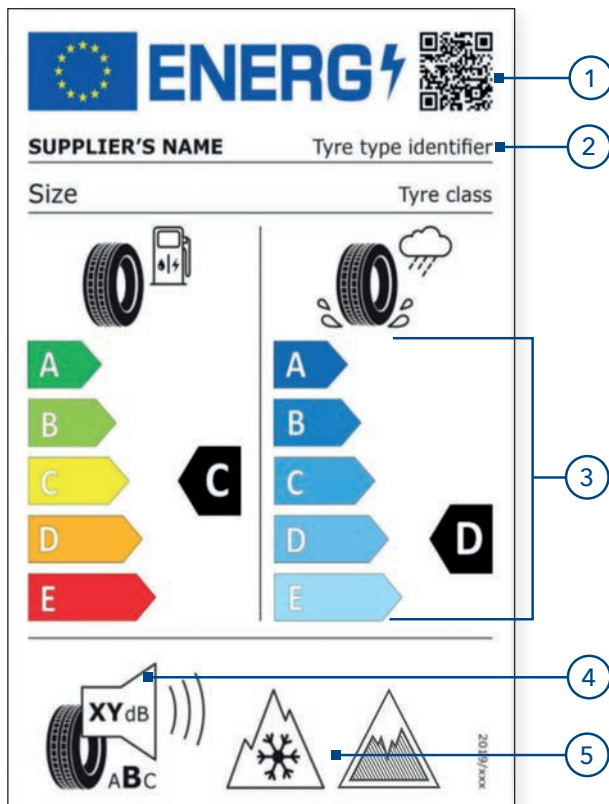

EU-Label für produzierte Reifen ab dem 01.05.2021

- 1 **QR-Code** leitet zur EU-Produktdatenbank (EPREL)
- 2 **Zusatz der Reifentypkennung = Art.-Nr.**
- 3 **Neuskalierung der unteren Labelwerte**
Die Label-Klassen E und F werden zu der Label-Klasse D. Die Label-Klasse G fusioniert zur Label-Klasse E. Auf der linken Seite des Reifenlabels erfolgt die Angabe des Rollwiderstands. Auf der rechten Seite die Angabe der Nasshaftung.
- 4 **ABC-Klassifizierung der Geräusche-Klassen anstatt Schallwellen**
Der Dezibel-Wert wird weiterhin angegeben
- 5 **Darstellung der Piktogramme**
Angabe des Schneegriffigkeit-Piktogramms (3PMSF) und Eisgriffigkeit-Piktogramms (nur für Reifen der Klasse C1)

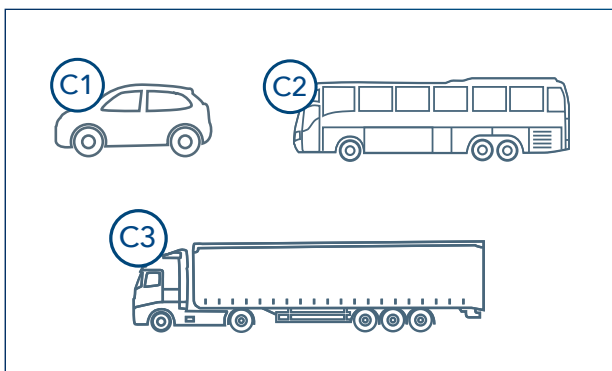

Einteilung der Klassen in C1, C2 und C3

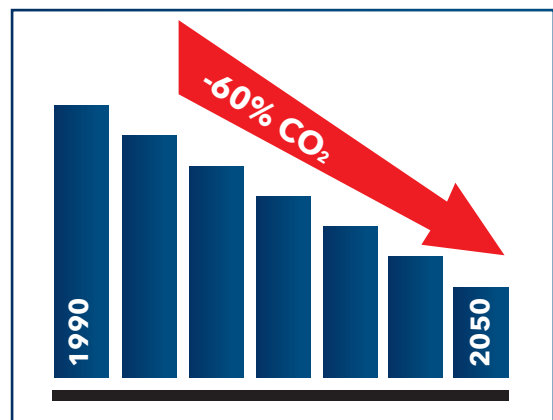

Reifen für die richtige Position

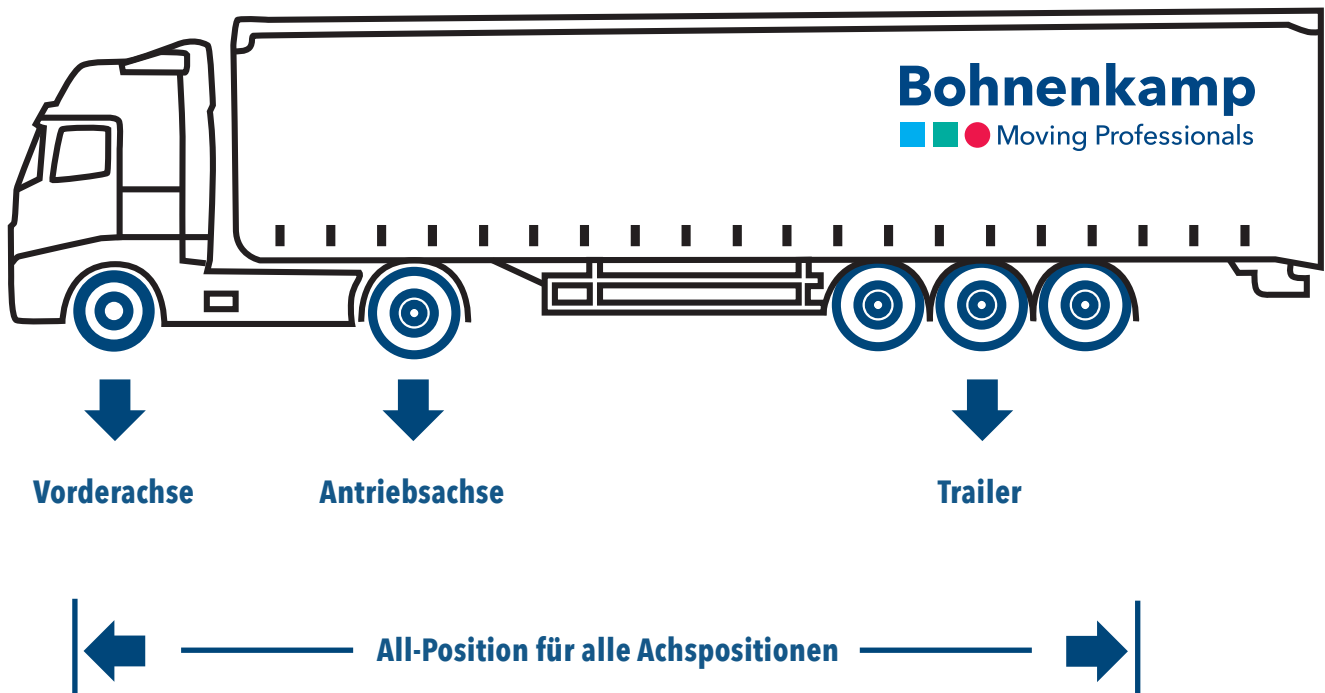

Vorderachse

Der Vorderachsreifen muss aufgrund der direkten Verbindung mit der Lenkachse besondere Anforderungen erfüllen. Profile für die Lenkachse haben daher meist gerade verlaufende Längsrillen, die einen schienenähnlichen Effekt bewirken. Sie müssen bei Geradeausfahrten Richtungsstabilität und in den Kurven Spurstabilität bieten.

Antriebsachse

Die Reifen der Antriebsachse tragen meist die größte Last. Sie müssen sowohl die Traktion für die Beschleunigung auf die Straße bringen, als auch die Bremskräfte und Verzögerungen durch den Motor bei einer Gaswegnahme auf den Untergrund übertragen. Diese Profile haben daher meist ein verzahntes, blockartiges Profil und müssen ab 2021 mit dem 3PMSF-Symbol gekennzeichnet sein.

Trailer

Ihre Aufgabe ist es, das Gewicht des Fahrzeugs zu verteilen und mehr Bremsleistung auf die Strecke zu übertragen. Auch diese Reifen verfügen meist über ein Längsrillenprofil, um dem Fahrzeug Seitenstabilität bei Querkräften zu verleihen.

All-Position

Reifen mit einem derartigen Profil sind auf allen Achsen zulässig. Durch ihr besonderes Profildesign sind sie multifunktional einsetzbar. Vorzugsweise werden sie im Nah-/Baustellenverkehr oder im Regioeinsatz gefahren.



Grundlagen Reifen

LKW-Reifenkennzeichnung

Die Kennzeichnungen eines LKW-Reifens verraten alles über den jeweiligen Reifen. Neben der genauen Reifengröße, Angaben zum Aufbau und seinen Leistungsgrenzen finden Sie viele weitere Informationen, die den gesetzlichen Vorgaben entsprechen.

1 Name des Herstellers

9 Herkunftsland

1

2 Nachschneidbar (Regroovable)

10 Last- und Geschwindigkeitsangaben

2

3 ECE-Prüfzeichen

11 Profilname

3

4 Code für Woche und Jahr

12 M+S/Traktionskennzeichnung

4

5 DOT-Nummer

13 Schlauchlos

5

6 Seriennummer

6

7 Nominelle Tragfähigkeitskennzahl

7

8 Größe

8

9



Reifenbreite
Höhen-Breiten-Verhältnis
Bauart
Felgendurchmesser

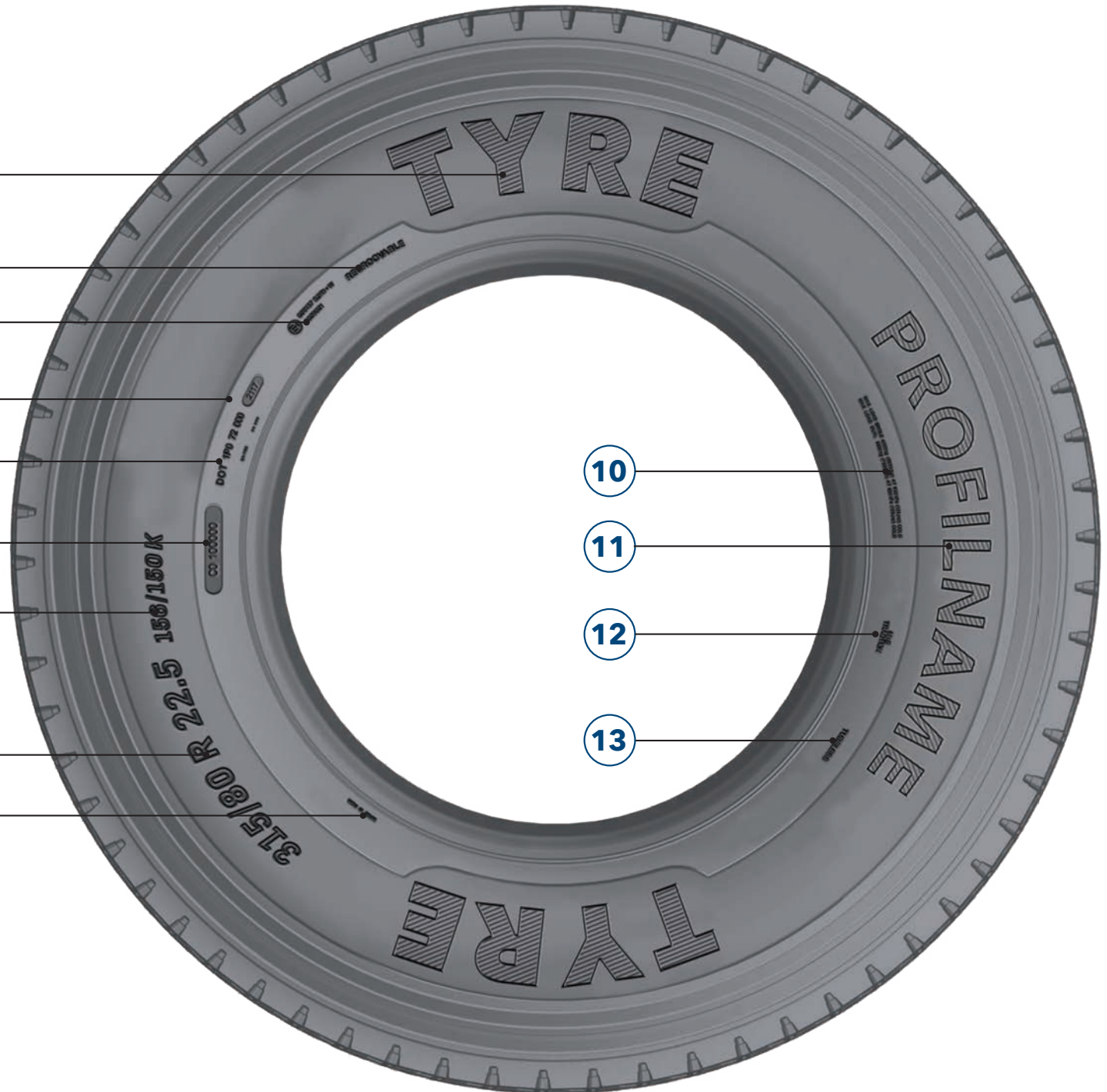

10

11

12

13



Grundlagen Felgen

Bezeichnungen und Abmessungen von Felgen

Nach der Definition der Hersteller besteht das Rad aus der Felge und der Schüssel. Das Felgenprofil ist genormt, damit der korrekte und sichere Sitz zwischen Felge und Reifen gewährleistet ist.

In der Praxis wird normalerweise die Kombination aus Felgenring und Schüssel als Felge und die Kombination aus Felge und Reifen als Rad bezeichnet. Diese sind auch die Bezeichnungen, die für den folgenden Teil gelten.

Die Bezeichnungen von Felgen sind genormt. Hierfür gelten folgende Definitionen:

Maulweite

Die Maulweite (Felgenbreite) wird zwischen den Felgenhörnern gemessen.

Felgendurchmesser

Der Felgendurchmesser wird zwischen den Felgenschultern ermittelt. Er entspricht dem Innendurchmesser des zu verwendenden Reifens und wird in Zoll angegeben.

Felgenausführung

Je nach Form des Felgenrings wird u.a. zwischen Tiefbettfelge (W), Doppeltiefbettfelge (DW) oder Dreifachtiefbettfelge (TW) unterschieden. Je nach Einsatzbereich werden noch weitere Ausführungen verwendet.

Felgenhorn

Das Felgenhorn hält die Reifenwulst im aufgepumpten Zustand des Reifens fest. Je nach Höhe des Felgenhorns unterscheidet man sechs verschiedene Codes (siehe Infobox).

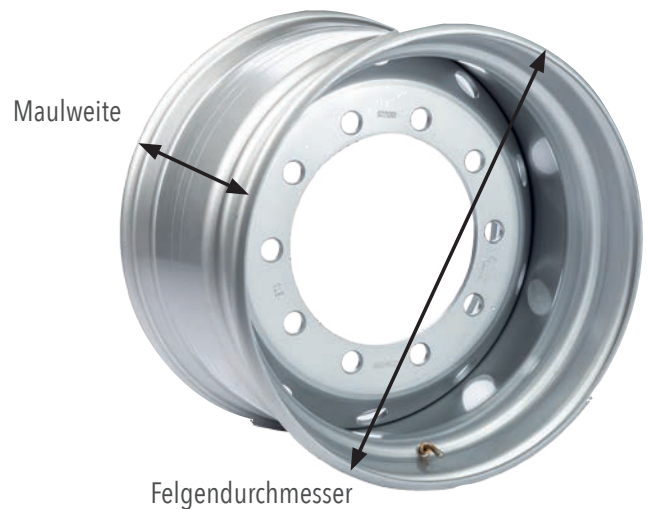

**Expertenwissen
kompakt**

Beispiele:

Codes für die Felgenausführung:

W = Tiefbett
DW = Doppeltiefbett
TW = Dreifachtiefbett

Codes für die Felgenhornhöhe:

D = 17,5 mm
E = 19,8 mm
F = 22,2 mm

Einpresstiefen

Die Einpresstiefe ist das Maß von der Felgenmitte bis zur inneren Anlagefläche der Felgenschüssel, wo das Rad an der Nabe befestigt wird. Die Einpresstiefe kann als positiv (+) oder als negativ (-) bezeichnet werden.

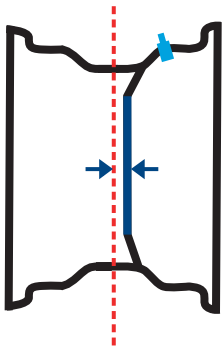

positive
Einpresstiefe

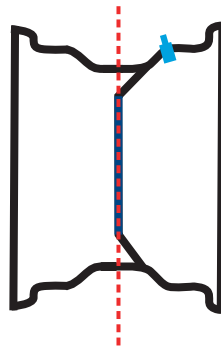

Einpresstiefe 0

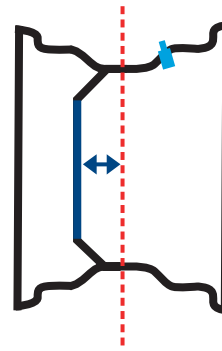

negative
Einpresstiefe

Innen- und außenliegende Ventile

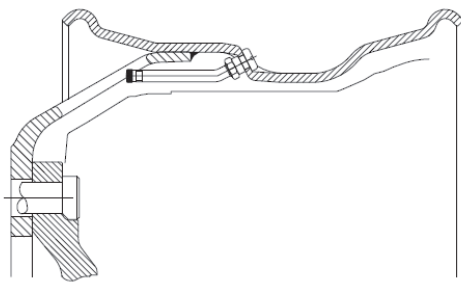

Innenliegendes Ventil (ILV)

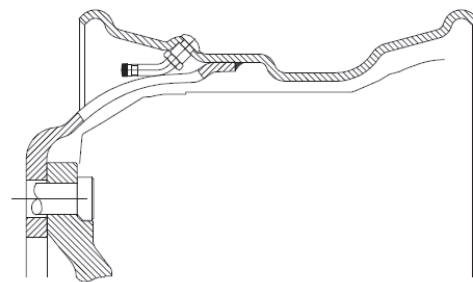

Außenliegendes Ventil (ALV)

Innenliegendes Ventil:

Die Ventilbohrung befindet sich auf der Innenseite der Schüssel. Das Ventil wird in der Regel durch eine Aussparung nach außen geführt.

Achtung: Bei ILV ist immer die Freigängigkeit der Bremse zu prüfen.

Außenliegendes Ventil:

Die Ventilbohrung befindet sich auf der Außenseite der Schüssel. Eine Freigängigkeit der Bremse stellt in der Regel kein Problem dar.





Grundlagen Felgen

Bolzenlöcher

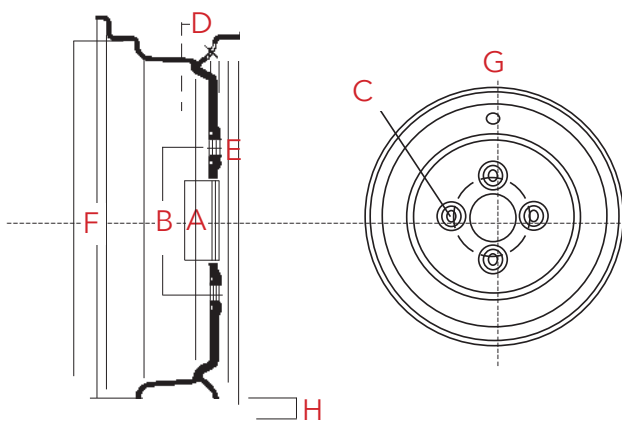
Felgen mit Bolzenanschluss haben ein Mittelloch und mehrere Bolzenlöcher zur Befestigung an der Nabe. Bei der Befestigung der Räder an der Nabe ist es von größter Wichtigkeit, dass die Muttern festgezogen und nach kurzer Gebrauchszeit erneut nachgezogen werden. Bolzen und Muttern müssen regelmäßig kontrolliert werden; die Häufigkeit der Kontrollen ist abhängig von der Intensität des Gebrauchs.

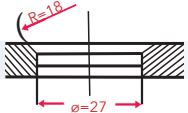

A	=	Mittellochdurchmesser mm
B	=	Bolzenlochkreis mm
C	=	Bolzenlochzahl
D	=	Einpresstiefe mm
E	=	Bolzenlochdurchmesser mm
F	=	Felgendurchmesser Zoll
G	=	Felgenmaulweite Zoll
H	=	Felgenhorn

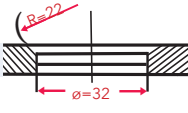
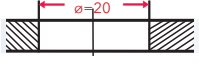
B3		für 20/22er Bolzen	B2		für 18er Bolzen IHC/Deutz/Schlüter
B5		für 28,6 mm Bolzen Same/Ford	Ø 20 Zyli.		für 18er Bolzen John Deere

Bolzenlochbezeichnung nach EUWA ES 3.15

M	22				Durchgangsloch
M	22	I	S	36	Kugel-/Kegelversenk
B		E	C	80	
		D			

Kugeldurchmesser
Kegelwinkel

S = Kugel (sphere)
C = Kegel (cone)

Ansenkung
I = innen (inside)
E = außen (external)
D = beidseitig (double side)

Bolzendurchmesser

M = Mitten-/Mischzentrierung
B = Bolzenzentrierung

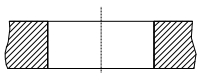

M22

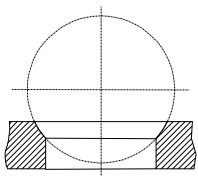

M22IS36

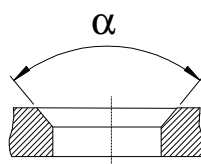

B23EC80

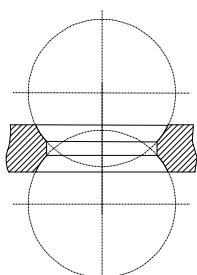

B18DS32

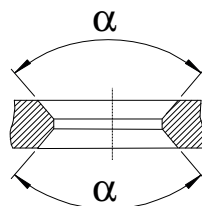

M23DC80

EUWA= Association of European Wheel Manufacturers

Für Räder mit Bolzenzentrierung (Kugelansenkung)

nach EUWA	alter Standard	d1	d2	Kugel- \emptyset	Gewinde
B14 DS 28	B1	18,5	24	28	M14 x 1,5
B14 ES 28	A1	18,5	24	28	M14 x 1,5
B18 DS 32	B2	21,5	27	32	M18 x 1,5
B18 ES 32	A2	21,5	27	32	M18 x 1,5
B22 DS 36	B3	27	32	36	M22 x 1,5 (M20 x 1,5)
B22 ES 36	A3	27	32	36	M22 x 1,5 (M20 x 1,5)
B19 DS 44,4	B5	32,5	37,5	44,4	3/4"
B19 ES 44,4	A5	32,5	37,5	44,4	3/4"

Für Räder mit Doppelzentrierung (Kugelansenkung)

nach EUWA	alter Standard	d1	d2	Kugel- \emptyset	Gewinde
M18 DS 32	B2	21,5	27	32	M18 x 1,5
M18 ES 32	A2	21,5	27	32	M18 x 1,5
M22 DS 36	B33	26	32	36	M22 x 1,5 (M20 x 1,5)
M22 ES 36	A33	26	32	36	M22 x 1,5 (M20 x 1,5)
M19 DS 44,4	B5	32,5	37,5	44,4	3/4"
M19 ES 44,4	A5	32,5	37,5	44,4	3/4"

Für Räder mit Bolzenzentrierung (Kegelansenkung)

nach EUWA	alter Standard	d1	d2	Kugel- \emptyset	Gewinde
B23 DC 80	B17	25,4	31	80°	7/8"
B23 EC 80	A17	25,4	31	80°	7/8"

Für Räder mit Doppelzentrierung (Kegelansenkung)

nach EUWA	alter Standard	d1	d2	Kugel- \emptyset	Gewinde
M23 DC 80	B37	26	31	80°	7/8"
M23 EC 80	A37	26	31	80°	7/8"

Für Räder mit Mittelzentrierung (zylindrische Bolzenlöcher)

nach EUWA	alter Standard	d1	d2	Kugel- \emptyset	Gewinde
M18	\emptyset 21				M18 x 1,5
M20	\emptyset 24				M20 x 1,5
M22	\emptyset 26				M22 x 1,5

Technische Daten

Speedindex

Kennbuchstabe	zul. km/h	Kennbuchstabe	zul. km/h
C	60	M	130
D	65	N	140
E	70	P	150
F	80	Q	160
G	90	R	170
J	100	S	180
K	110	T	190
L	120		

Loadindex

LI	KG	LI	KG	LI	KG	LI	KG	LI	KG	LI	KG
99	775	112	1120	125	1650	138	2360	151	3450	164	5000
100	800	113	1150	126	1700	139	2430	152	3550	165	5150
101	825	114	1180	127	1750	140	2500	153	3650	166	5300
102	850	115	1215	128	1800	141	2575	154	3750	167	5450
103	875	116	1250	129	1850	142	2650	155	3875	168	5600
104	900	117	1285	130	1900	143	2725	156	4000	169	5800
105	925	118	1320	131	1950	144	2800	157	4125	170	6000
106	950	119	1360	132	2000	145	2900	158	4250	171	6150
107	975	120	1400	133	2060	146	3000	159	4375	172	6300
108	1000	121	1450	134	2120	147	3075	160	4500	173	6500
109	1030	122	1500	135	2180	148	3150	161	4625	174	6700
110	1060	123	1550	136	2240	149	3250	162	4750	175	6900
111	1090	124	1600	137	2300	150	3350	163	4875	176	7100

Veränderung der Ladekapazität

Geschwindigkeit (km/h)	Geschwindigkeitssymbol						Druckausgleich (%)
	Speedsymbol F	Speedsymbol G	Speedsymbol J	Speedsymbol K	Speedsymbol L	Speedsymbol M	
Static	+ 150.0	+ 150.0	+ 150.0	+ 150.0	+ 150.0	+ 150.0	+ 40
5	+110.0	+110.0	+110.0	+110.0	+110.0	+110.0	+ 40
10	+ 80.0	+ 80.0	+ 80.0	+ 80.0	+ 80.0	+ 80.0	+ 30
15	+ 65.0	+ 65.0	+ 65.0	+ 65.0	+ 65.0	+ 65.0	+ 25
20	+ 50.0	+ 50.0	+ 50.0	+ 50.0	+ 50.0	+ 50.0	+ 21
25	+ 35.0	+ 35.0	+ 35.0	+ 35.0	+ 35.0	+ 35.0	+ 17
30	+ 25.0	+ 25.0	+ 25.0	+ 25.0	+ 25.0	+ 25.0	+ 13
35	+ 19.0	+ 19.0	+ 19.0	+ 19.0	+ 19.0	+ 19.0	+ 11
40	+ 15.0	+ 15.0	+ 15.0	+ 15.0	+ 15.0	+ 15.0	+ 10
45	+ 13.0	+ 13.0	+ 13.0	+ 13.0	+ 13.0	+ 13.0	+ 9
50	+ 12.0	+ 12.0	+ 12.0	+ 12.0	+ 12.0	+ 12.0	+ 8
55	+ 11.0	+ 11.0	+ 11.0	+ 11.0	+ 11.0	+ 11.0	+ 7
60	+ 10.0	+ 10.0	+ 10.0	+ 10.0	+ 10.0	+ 10.0	+ 6
65	+ 7.5	+ 8.5	+ 8.5	+ 8.5	+ 8.5	+ 8.5	+ 4
70	+ 5.0	+ 7.0	+ 7.0	+ 7.0	+ 7.0	+ 7.0	+ 2
75	+ 2.5	+ 5.5	+ 5.5	+ 5.5	+ 5.5	+ 5.5	+ 1
80	0	+ 4.0	+ 4.0	+ 4.0	+ 4.0	+ 4.0	0
85		+ 2.0	+ 3.0	+ 3.0	+ 3.0	+ 3.0	0
90		0	+ 2.0	+ 2.0	+ 2.0	+ 2.0	0
95			+ 1.0	+ 1.0	+ 1.0	+ 1.0	0

Bohnenkamp AG Osnabrück Tel.: +49 541 12163-0

Niederlassung Landshut Tel.: +49 8703 938

Niederlassung Kletzin Tel.: +49 399 9831

Vertriebsbüro Leipzig Tel.: +49 341 39299

Vertriebsbüro Lüneburg Tel.: +49 4131 29895

Vor Ort und international für Sie da.
Die Bohnenkamp Unternehmensgruppe



21.0008 - Irrtümer vorbehalten



**TRUCK &
TRANSPORT**

Bohnenkamp

■ ■ ● Moving Professionals

www.bohnenkamp.com